

Data Sheet

EC-LTS1200-400

Liquid cooled heavy duty converter

FEATURES

- Extremely compact design: 3 x 170 A unit only 58 kg
- High enclosure class IP65 – sealed from moisture and dust
- Liquid cooled with plain water or water/glycol mixture
- Ambient temperature up to +85 °C and down to -40 °C
- Allowed coolant temperature up to +65 °C
- Robust design withstanding high levels of mechanical vibrations and shocks
- Designed especially for highly cyclical loads typical in heavy mobile work machines



GENERAL

The device is a heavy-duty external inductance unit designed to be combined with EC-C1200 DCDC-converter. It allows flexible positioning of the DCDC-converter and inductor unit and is used to transfer energy between two different voltage levels.

Typical applications:

- Boosting battery voltage to higher DC-link voltage
- Charging high voltage batteries from higher DC-link voltage

SPECIFICATIONS

DC connection

DC link voltage range 0-850 VDC

DC link nominal voltage 750 VDC

Nominal current per inductor 135 A (65 °C coolant)

Maximum current per inductor 170 A (40 °C coolant)

Mechanical

Dimensions (WxHxL, mm) 290x197x665
 308x197x665 (with +CG1 option)

Weight 58 kg

Cooling

Cooling liquid Plain water with appropriate corrosive inhibitor (max. 50 % corrosive inhibitor)

Cooling liquid glycol type Ethylene glycol (Glysantin G48 recommended)

Minimum cooling liquid flow 10 l/min

Maximum continuous pressure 2 bar

Pressure loss 45 mbar with 10l/min (+25°C coolant)

Cooling liquid temperature -40°C ...+65°C

Ambient Conditions

Storage temperature -40°C...85°C

Operating temperature -40°C...85°C (with nominal coolant temp.)

Altitude max. 2000 m

Relative humidity 100 %

Enclosure class IP65

Mechanical vibration 5 G, CEI EN 61373 category 2

IEC 60068-2-6 (2007-12, Test Fc)
 10...57 Hz: amplitude 0.075mm
 58...150 Hz: 1 G

5...13.2 Hz: max. 1 mm
 13.2...100 Hz: 0.7G (sinusoidal)

Mechanical shock 30 G, CEI EN 61373 category 2

Connections

Coolant connection 2 x G1/2" coolant hose connector

HV cable recommended type HUBER+SUHNER Radox Elastomer S screened automotive cable
www.hubersuhner.com

HV cable cross section ≤70 mm² (Cu)

HV cable glands (with +CG1/+CG2 option) Pflitsch blueglobe TRI bg 225ms tri

HV cable lug size 35-8, 50-8, 70-8

Recommended cable lug 50mm²: Druseidt part no. 10853
 70mm²: Druseidt part no. 10857
www.druseidt.de

PRESSURE LOSS VS COOLANT FLOW

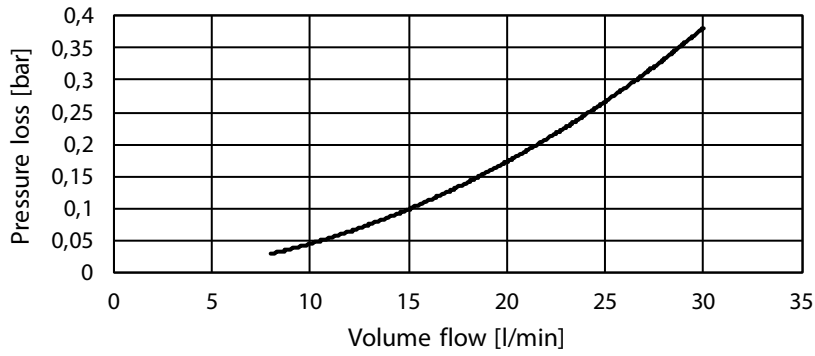

Picture 1 Device pressure loss vs coolant flow

DIMENSIONS

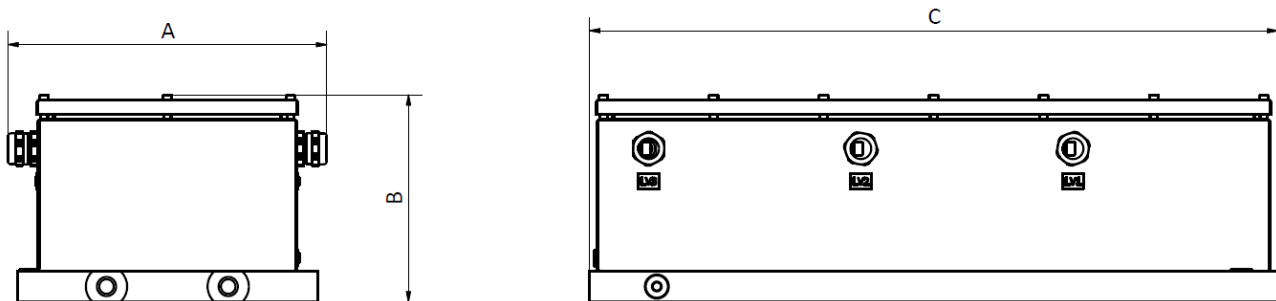

Picture 2 Device dimensions with +CG1 option

Dimension	Device dimensions
A	308 mm
B	200 mm
C	665 mm

Table 1 Device dimensions with +CG1 option

APPLICATION EXAMPLE

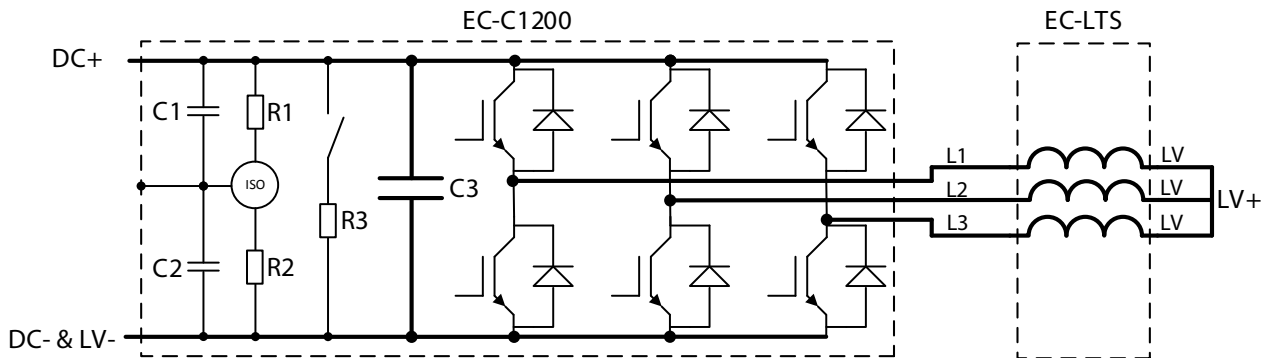

Picture 3 EC-C1200 DCDC converter combined with the EC-LTS unit. LV+ and LV- can be connected for example to battery and DC+ and DC- to DC-link. EC-C1200 would then control the battery discharging and charging.

PRODUCT CODE AND OPTIONS

Use product code including all needed options for ordering. Standard options do not need to be listed in the code as they are selected by default if a non-standard option is not selected. EC-LTS is designed to be used in combination with the EC-C inverters.

Product code	Description
EC-LTS1200-400+CG1	Standard unit with 6x M25 cable glands
EC-LTS1200-400+PC+CG3	Unit with parallel connected inductors and 4x M25 cable glands and 2x plugs

Table 2 Product code examples

Variant	code	Description		Additional description
Parallel connection	*	No parallel connection busbar	s	Separate inductors
	+PC	Parallel connection busbar	o	Parallel connected inductors
Temperature sensors	*	No temperature sensors	s	
	+TEMP1	One PT100 sensor per inductor	o	One PT100 sensor per inductor and M12 cable gland. Connection strip inside the device.
Glands	*	No glands	s	No cable glands or plugs
	+CG1	M25 cable glands	o	6x M25 cable glands in delivery
	+CG2	M25/M12 cable glands	o	4x M25 and 1x M12 cable glands and 2x plugs in delivery (for combined +TEMP1 and +PC option)
	+CG3	M25 cable glands	o	4x M25 cable glands and 2x plugs in delivery (for +PC option)
	+CG4	M25/M12 cable glands	o	6x M25 cable glands and 1x M12 cable glands in delivery (for +TEMP1 option)

Table 3 Option list

Danfoss can accept no responsibility for possible errors in catalogues, brochures and other printed material. Danfoss reserves the right to alter its products without notice. This also applies to products already on order provided that such alterations can be made without changes being necessary in specifications already agreed. All trademarks in this material are property of the respective companies. Danfoss and the Danfoss logotype are trademarks of Danfoss A/S. All rights reserved.