

ECM2020 Edge Computing Module



- 2 x 10/100 BaseT Ethernet
- 3 x CAN interfaces
- USB Interface
- RS232 interface
- Configurable I/O's
- External display connector
- Programmable via Guitu
- Designed to operate with both 12 VDC and 24 VDC
- Real Time Clock
- WiFi or 3G (including GPS)
- Operating voltage 9-32 VDC

ECM2020 Edge Computing Module is compact and versatile high-performance computing unit with comprehensive interfaces. It includes computational capacity to perform edge analytics and enough memory to store the data locally when network connection is not temporarily available.

Wired interfaces include 2 x ethernet, 3 x CAN buses, USB, RS-232, analog inputs, digital IO and connector for external display.

ECM2020 can be equipped optionally with wireless interfaces compatible with WiFi or 3G operator networks (works also in typical 4G networks). Full speed LTE support will be coming later. 3G version will be delivered without SIM-card and it can be installed by opening the cover plug on the front cover. GPS is included in 3G option.

The design is robust with milled aluminium case and it is targeted for heavy machinery industries.

Technical Information

- ARM Cortex A9 800 MHz main CPU
 - 1 GB DDR3 RAM
 - 8 GB flash memory
- External screen connector
- 3 x CAN Interface 2.0 B, ISO 11898
- WiFi or 3G connection
- GPS (included in 3G-option)
- 100 Mb Ethernet
- 4 configurable I/Os
- Reference voltage output
- Real time clock (RTC)
- Three programmable LEDs
- IP67 aluminium housing
- 9 - 32 VDC Operating voltage range (Protected against reverse polarity)
- -40...+85 °C operating temperature range (WLAN-version -20 ... +70 °C)
- Main dimensions: 195 mm(l) x 145 mm(w) x 53 mm(h)
- Weight 1,2 kg

I/O Interface

Amount	Configurability	Details
1	Reference voltage (USB 5 V out)	5 V, max. 250 mA
4	Digital input (PNP) Analog input	Low < 1,6 V, High > 3,1 V, max 100 Hz 12-bit AD conversion, 0-10,3 V, 69 kΩ, 0-22 mA, 150 Ω.
6	Digital input (PNP)	Low < 2 V, High > 6 V, max 100 Hz

Note

- If CAN 3 is selected as active, it consumes 2 input pins
- If RS232 is selected as active, it consumes 2 input pins

Wiring Diagram for M12 connectors (X1 through to X6 and X9):

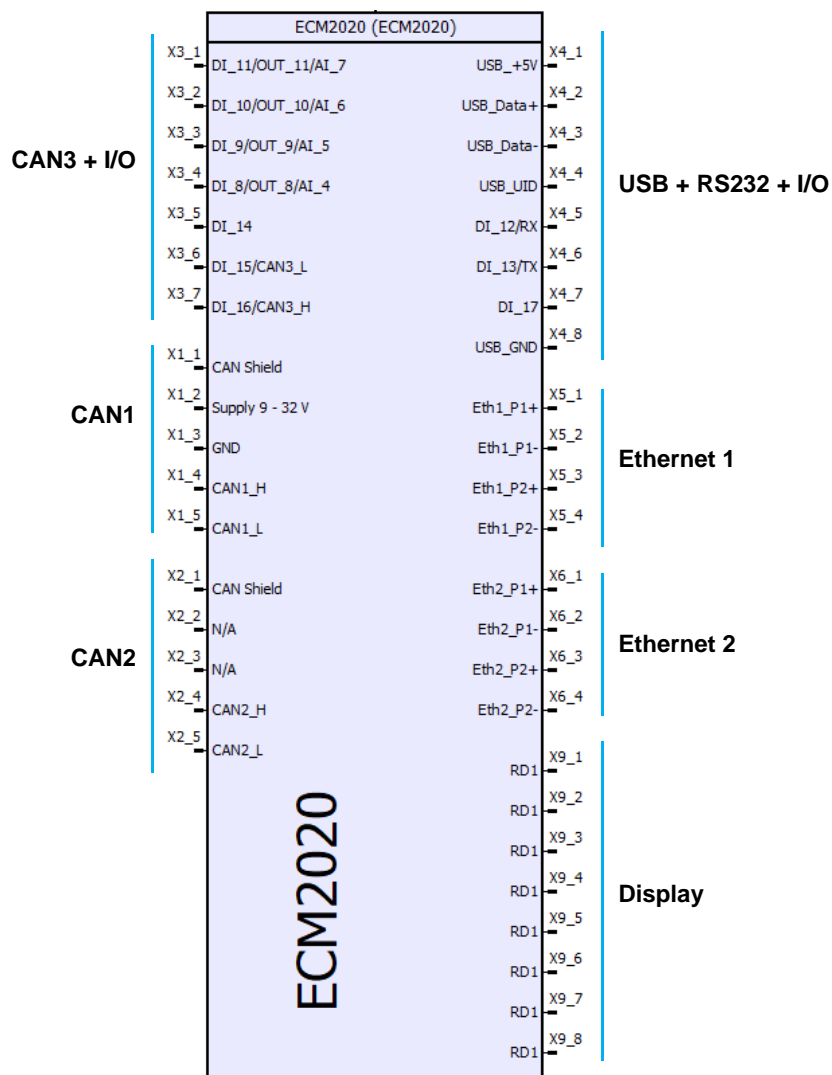

Connectors location

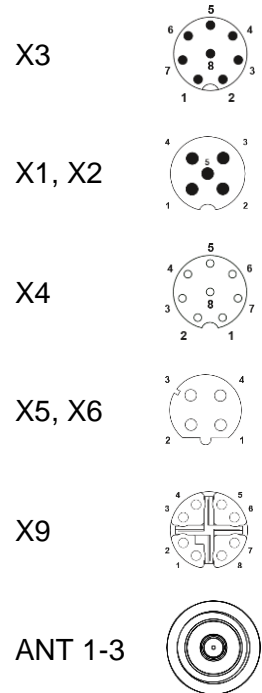
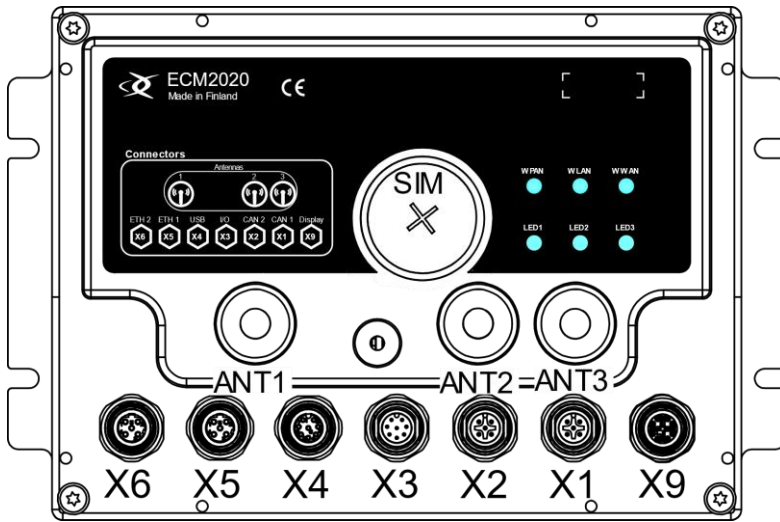

Connectors

Connector needed:

X1: CAN 1	M12 5 pin, Female A-coded
X2: CAN 2	M12 5 pin, Female A-coded
X3: CAN 3 + I / O	M12 8 pin, Female A-coded
X4: USB + I / O	M12 8 pin, Male A-coded
X5: Ethernet 1	M12 4 pin, Male D-coded
X6: Ethernet 2	M12 4 pin, Male D-coded
X9: Remote Touch Display	M12 8 pin, Male X-coded
ANT1: WiFi max 1,5 Mbs	RPSMA male ¹
ANT2: Wifi or 3G	RPSMA male (Wifi), SMA male(3G) ¹
ANT3: Wifi or 3G	RPSMA male (Wifi), SMA male(3G) ¹
Protective cap for Male M12 ²	Erni 374342
Protective cap for Female M12 ²	Erni 374343

1. To maintain IP-rating, contact Exertus for a special SMA-connector.

2. Protective caps must be used on unused connectors to reach waterproofness

As seen from cable entry side

Mounting and Housing Information

ECM200 is fastened to flat surface using four M5 size screws.

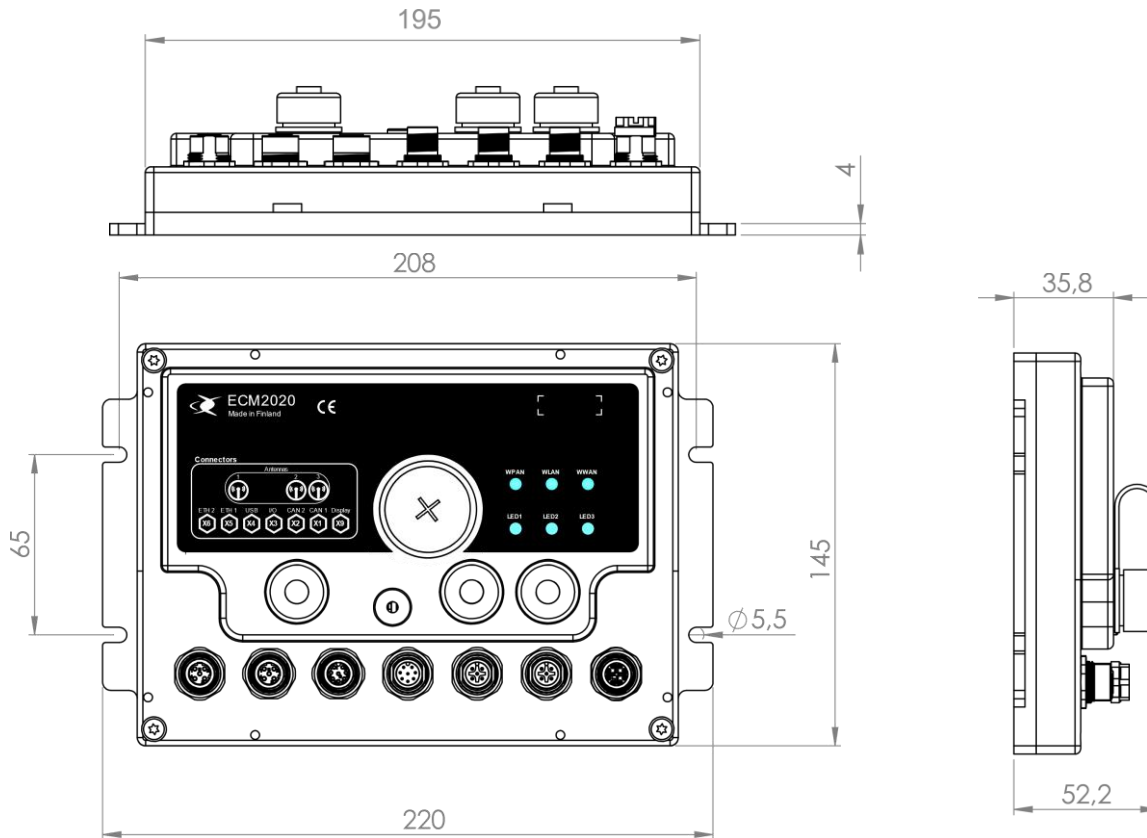

The preferred mounting position is connectors pointing downwards. If the unit is mounted connectors pointing to the side, then it is vital to leave some loose cable with a downward cue to prevent the ingress of moisture through connector.

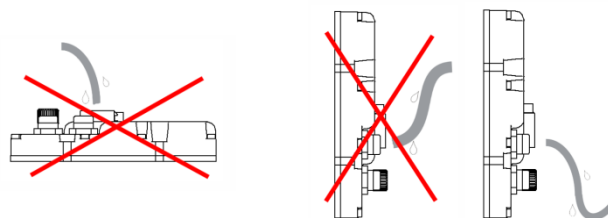

Tests & CE compliance – tests still pending

EMC	<p>EN 61000-4-2, Testing and measurement techniques – Electrostatic discharge immunity test</p> <p>E/ECE Regulation No. 10, Revision 4 (2012), Emission and immunity tests</p> <p>IEC 60255-22-1, Electrical disturbance tests for measuring relays and protection equipment – 1 MHz burst immunity test</p>
Environmental	<p>EN 60068-2-1, Cooling test</p> <p>IEC 60068-2-2, Dry heat test</p> <p>IEC 60068-2-30, Damp heat test</p> <p>EN 60068-2-6, Stationary vibration</p> <p>EN 60068-2-27, Mechanical shock test</p> <p>IEC 60529, IP6X dust test</p> <p>IEC 60529, IPX7 temporary immersion test to 1m</p> <p>ISO 9227, Salt spray test</p>