

## CAST IRON PUMPS AND MOTORS **W3 SERIES**

POMPE E MOTORI IN GHISA SERIE W3

MADE IN ITALY



REV MARZO 15

La Ronzio Oleodinamica fu fondata nel 1950 da Dante Ronzio esperto in meccanica di precisione.

La prima attività dell'azienda fu la lavorazione di pompe per motori diesel, seguita, qualche anno più tardi, dalla costruzione di pompe oleodinamiche ad ingranaggi, che presto divenne la produzione prevalente.

La passione del fondatore per la meccanica fine ha lasciato nella Ronzio Oleodinamica un'impronta significativa; il motto dell'azienda è sempre stato quello di operare all'insegna della qualità e precisione, sia nell'impiego delle materie prime sia nel controllo del processo produttivo.

La Ronzio Oleodinamica produce ora pompe, motori e divisori di flusso che trovano impiego in molti settori industriali sia nel veicolo che negli impianti fissi, nelle macchine agricole, forestali e nel movimento terra.

La struttura snella della nostra azienda e la nostra esperienza sono la risposta ai clienti che cercano in noi non solo un fornitore ma un partner nello sviluppo dei loro progetti.

Il nostro sistema qualità è certificato da DNV dal 1998.

*Ronzio Oleodinamica was established in 1950 by Mr. Dante Ronzio, fond of precision mechanics.*

*The Company started its activity machining pumps for diesel motors. The passion of the founder for fine mechanics left an important mark in the Company. The production of hydraulic gear pumps started some years later, and became soon the main activity of the Company.*

*Since the beginning Ronzio Oleodinamica has been focusing on quality and precision. Our Company uses top quality components, and the most advanced computerized machines, in both the production and the testing process.*

*Ronzio Oleodinamica manufactures gear pumps, motors and flow dividers in aluminium and in cast iron for a wide range of industries including: construction, forestry, agriculture, industrial vehicle, earth moving, industrial.*

*Today, our products are worldwide appreciated.*

*Our experience and our lean structure are suitable for customers who need a direct involvement of the supplier in their projects.*

### **Caratteristiche principali**

- Corpi e coperchi in ghisa per maggiori prestazioni
- Possibilità di funzionare ad alte pressioni: fino a 300 bar di pressione massima in funzionamento continuo.
- Compensazione assiale per il recupero dei giochi
- Alto rendimento volumetrico: >95%
- medio.
- Progetto accurato del profilo del dente per avere una bassa rumorosità.
- Vasta gamma di flange, alberi e connessioni compatibili con i principali standard del mercato.
- Disponibilità di guarnizioni per alte temperature
- Pompe e motori unidirezionali
- Pompe e motori bidirezionali
- Possibilità di montaggio di pompe multiple prodotte dalla Ronzio Oleodinamica

### **Main Features**

- *Cast iron covers and body for high performance*
- *High pressure option: up to 300 bar max. continuous pressure ( 4350 psi )*
- *Axial compensation achieved using pressure balanced bushing blocks.*
- *High volumetric efficiency: average 95%*
- *Gear tooth profile accurately projected providing low noise operation.*
- *A wide variety of shafts, flanges and ports are available to meet specific application requirements.*
- *High-temperature seals available.*
- *Single rotational pumps and motors.*
- *Bi-rotational pumps and motors.*
- *Multiple pumps availability: tandem pumps are possible both with other series produced by Ronzio Oleodinamica*

### **CONDIZIONI PER L'UTILIZZO DELLE POMPE E MOTORI "W3"**

#### **CONDITIONS OF USE FOR PUMPS AND MOTORS "W3"**

Nell'utilizzo della pompa evitare carichi radiali e assiali sull'albero, dove si verificano utilizzare gli appositi supporti illustrati in questo catalogo

Il giunto di trascinamento deve compensare eventuali errori di allineamento, deve essere di tipo elastico oppure di tipo Oldham.

Per un corretto funzionamento e una lunga durata della pompa, osservare i valori riportati nella tabella seguente.

*Avoid radial and axial loads on the pump shaft during the use, where it happens use outboard bearing illustrated in this catalogue.*

*The pump must be in line with the P.T.O. to compensate misalignment errors, use flexible or "Oldham" coupling.*

*We recommend to read the specifications in this catalogue very carefully. This will help you in getting the best, in terms of working conditions and life, from Ronzio gear pumps.*

## CONDIZIONI DI UTILIZZO USE CONDITIONS

<b>Fluidi idraulici</b> <i>Hydraulic fluids</i>	Oli idraulici a base minerale ( DIN 51524 ) Per utilizzo di fluidi non infiammabili come acqua e glicole , emulsione di olio in acqua, o esteri fosforici, contattare il nostro ufficio tecnico o commerciale  <i>Mineral oil ( DIN 51524 )</i> <i>For use with fire resistant fluids like water glycol, water- oil emulsion and phosphate-esters, contact our technical or commercial office.</i>		
<b>Pressione in aspirazione</b> <i>Inlet pressure</i>	0.7 - 3 bar ( Assoluti / Absolute ) 10 - 44 psi ( Assoluti / Absolute )		
<b>Velocità olio nella linea di aspirazione</b> <i>Oil speed on suction line</i>	0.5 ÷ 1.5 m/s		
<b>Velocità olio nella linea di mandata</b> <i>Oil speed on pressure line</i>	6 ÷ 10 m/s		
<b>Temperatura olio</b> <i>Oil temperature</i>	-10°C ÷ 80°C		
<b>Viscosità olio</b> <i>Oil viscosity</i>	20 ÷ 120 mm <sup>2</sup> / s ( Cst )		
<b>Massima viscosità olio all'avvio</b> <i>Max starting viscosity</i>	700 mm <sup>2</sup> / s ( Cst )		
<b>Filtraggio olio</b> <i>Oil filtration</i>	<b>Pressione</b> <i>Pressure</i>	<b>&lt; 200 bar</b>	<b>&gt; 200 bar</b>
	Classe di contaminazione NAS1638 <i>Contamination class NAS1638</i>	10	9
	Classe di contaminazione ISO 4406 <i>Contamination class ISO 4406</i>	19/16	18/15
	Rapporto β <sub>x</sub> ≥ 75 Ratio β <sub>x</sub> ≥ 75	25µm	10µm

## FORMULE PER DIMENSIONAMENTO DETERMINATION OF NOMINAL SIZE

PER POMPE  
*FOR PUMP*

$$Q = \frac{V \cdot \eta_v \cdot n}{1000}$$

$$M = \frac{p \cdot V}{62.8 \cdot \eta_m}$$

$$P = \frac{p \cdot Q}{600 \cdot \eta_t}$$

PER MOTORI  
*FOR MOTOR*

$$Q = \frac{V \cdot n}{1000 \cdot \eta_v}$$

$$M = \frac{p \cdot V \cdot \eta_m}{62.8}$$

$$P = \frac{p \cdot Q \cdot \eta_t}{600}$$

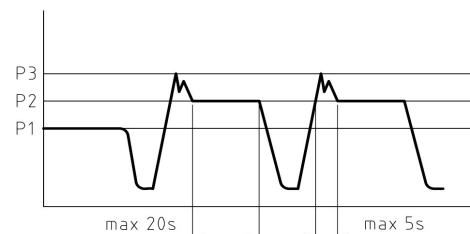

V [cm<sup>3</sup>]

Q [l/min]

p [bar]

M [Nm]

n [min<sup>-1</sup>]

P [Kw]

η<sub>v</sub> = EFF vol. ≥ 95

η<sub>m</sub> = EFF mecc. ~ 0.85

η<sub>t</sub> = η<sub>v</sub> · η<sub>m</sub>. ~ 0.8

## CARATTERISTICHE PRINCIPALI MAIN CHARACTERISTICS

Tipo - Type		15	20	25	30	35	40	45	50	55	60	64	70	80	90
Cilindrata Capacity	Om <sup>3</sup> / giro Om <sup>3</sup> / rev	15.5	19.9	24.9	29.9	34.3	40.5	45.2	49.9	54.5	60	63.9	70	78.7	89.6
Portata a 1500 giri / min Delivery at 1500 rev. / min	l / min l / min	25.9	29.9	37.4	44.9	51.5	60.8	67.8	74.9	81.8	90	95.9	105	118	134.4
P1 Pressione max continua Max working pressure	Bar	300	300	300	280	280	250	250	230	230	200	200	170	170	160
P2 Pressione intermittente intermittent pressure	Bar	320	320	320	300	300	270	270	250	250	220	220	190	190	180
P3 Pressione max di picco Max peak pressure	Bar	350	350	350	330	330	300	300	270	270	240	240	210	210	200
Velocità max per pressione P1 Max speed for P1 pressure	Giri / min Rpm	3000	3000	3000	2500	2500	2200	2200	2000	2000	2000	2000	1800	1800	1800
Velocità max a vuoto Max speed without load	Giri / min Rpm	3500	3500	3500	3000	3000	2800	2800	2500	2500	2500	2500	2200	2200	2200
Velocità min. per pressione P1 Min speed for P1 pressure	Giri / min Rpm	450	450	450	350	350	350	350	300	300	250	250	200	200	200

VERIFICARE, ATTRAVERSO LE FORMULE A PAGINA 4, LA COMPATIBILITÀ TRA LE PRESTAZIONI DI PRESSIONE E PORTATA RICHIESTE E LA CAPACITÀ DEL ALBERO DI TRASCINAMENTO DI SOPPORTARE LA COPPIA RICHIESTA

VERIFY THE COMPATIBILITY AMONG PERFORMANCE OF PRESSURE, FLOW REQUIRED AND TORQUE OF THE SHAFT THROUGH THE FORMULAS ON PAGE 4

Per pompe o motori bidirezionali, diminuire la pressione del 15%  
With bidirectional pumps or motors, pressure is reduced by 15%

## COMPONENTI

### PARTS

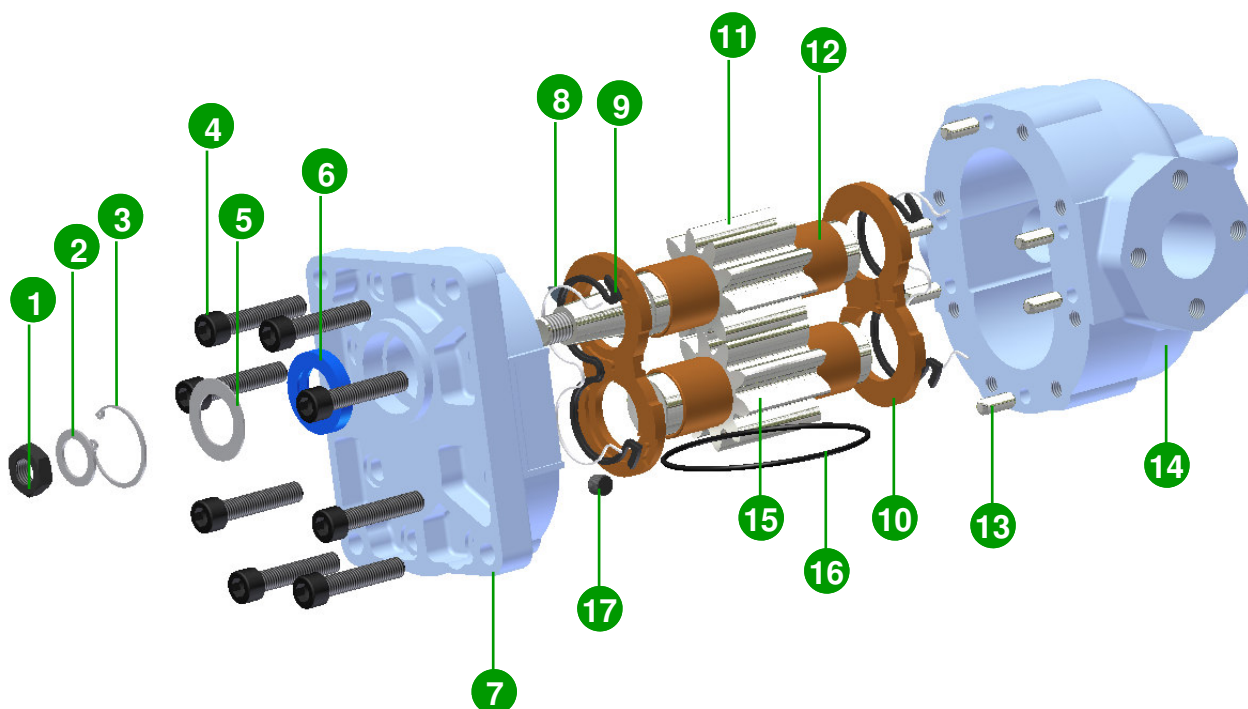

Rif.	Descrizione	Description	Qt.
1	Dado	Hexagonal nut	1
2	Rondella di sicurezza	Safety ring	1
3	Anello seeger	Snap ring	1
4	Vite	Bolt	8
5	Rondella anello di tenuta	Rotary shaft seal ring	1
6	Anello di tenuta	Rotary shaft seal	1
7	Coperchio	Front flange	1
8	Antiestrusore	B-K seals	2
9	Guarnizione di compensazione	Compensation seal	2
10	Rasamento	Thrust plates	2
11	Ingranaggio conduttore	Drive gear	1
12	Boccola	Bushing	4
13	Spina cilindrica	Pin	6
14	Corpo	Housing	1
15	Ingranaggio condotto	Idle gear	1
16	Guarnizione sotto coperchio	Under cover seal	1
17	Grano 1/8" G	Grub screw 1/8" G	1

## SENSO DI ROTAZIONE

### ROTATION

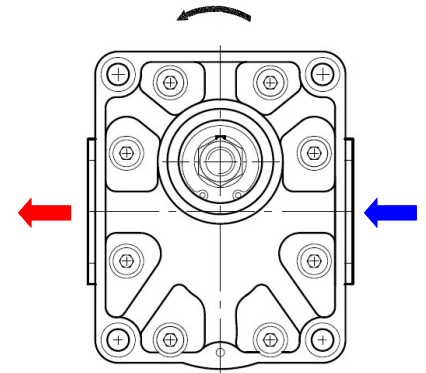
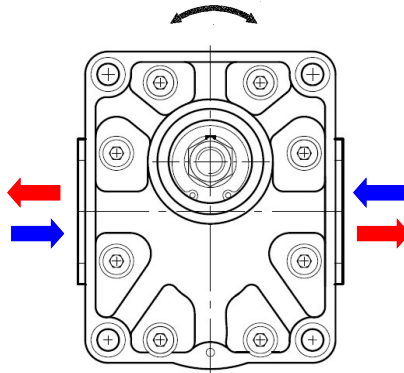
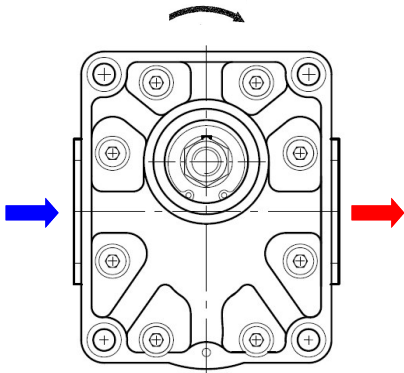

Rotazione destra <i>Clockwise rotation</i>	Codice Code	<b>D</b>
---	----------------	----------

Rotazione bidirezionale drenaggio esterno <i>Bidirectional rotation with external drain</i>	Codice Code	<b>R</b>
Rotazione bidirezionale drenaggio interno <i>Bidirectional rotation with internal drain</i>	Codice Code	<b>Y</b>

Rotazione sinistra <i>Anti-Clockwise rot.</i>	Codice Code	<b>S</b>
--	----------------	----------

Il senso di rotazione, è indicato con una freccia sul corpo della pompa.  
*Rotation, is indicated by an arrow on the body of the pump.*

## GUARNIZIONI PER ALBERI

### SHAFT SEAL

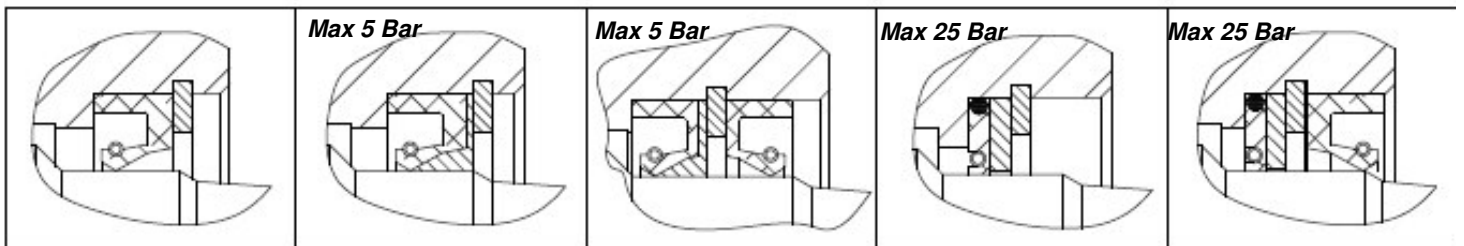

Codice Code	//	NBR
	<b>V</b>	VITON

Codice Code	<b>R*</b>	NBR
	<b>RV</b>	VITON

Codice Code	<b>N2</b>	NBR
	<b>V2</b>	VITON

Codice Code	<b>B</b>	//
----------------	----------	----

Codice Code	<b>BN</b>	NBR
	<b>BV</b>	VITON

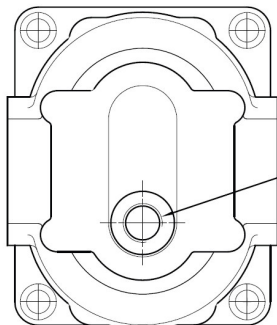

G3/8" - 9/16-18UNF-2B

G 3/8" PER BOCCHE GAS E METRICHE.  
9/16-18UNF-2B PER BOCCHE O-RING BOSS e SPLIT

G3/8" FOR GAS AND METRIC PORTS  
9/16-18UNF-2B FOR O-RING BOSS AND SPLIT PORTS

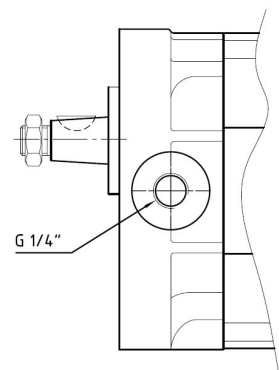

G 1/4"

Drenaggio posteriore per pompe o motori reversibili <i>Rear drain for bidirectional pumps or motors</i>	<b>R</b>
--	----------

Drenaggio anteriore per pompe o motori reversibili <i>Front drain for pumps or motors</i>	<b>R1</b>
--	-----------

\* il codice "R" comprende rotazione bidirezionale, paraolio rinforzato e drenaggio posteriore  
*Code "R" include bidirectional rotation, reinforced shaft seal and rear drain*

**CAM BIO DEL SENSO DI ROTAZIONE DELLE POM PEW3**  
**CHANGING ROTATION OF THE PUM P W3**

Rotazione destra  
 Clockwise rotation

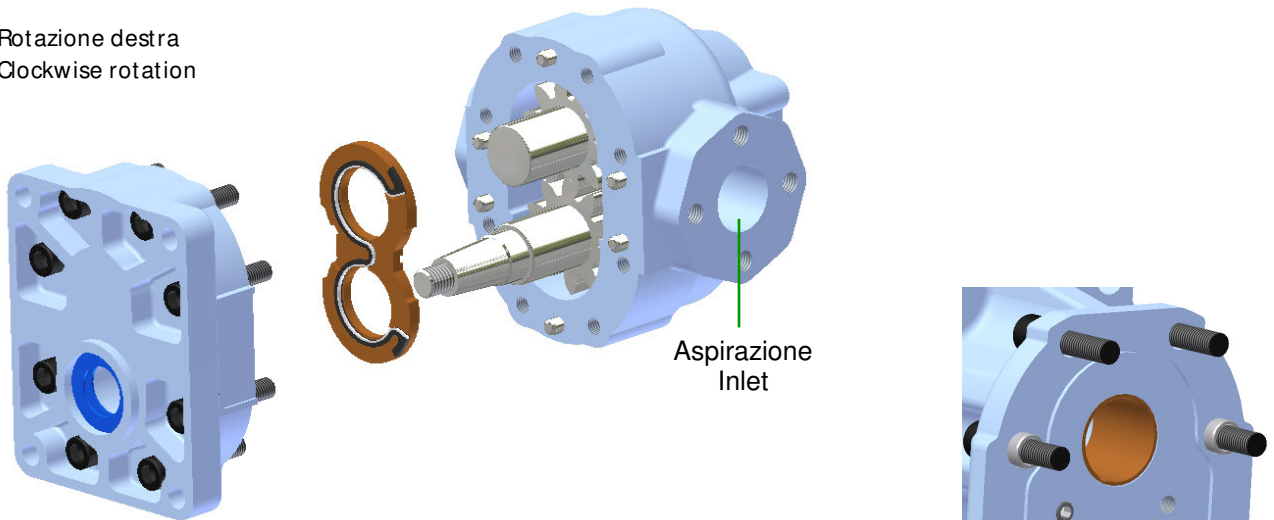

Rotazione sinistra  
 Anticlockwise rotation

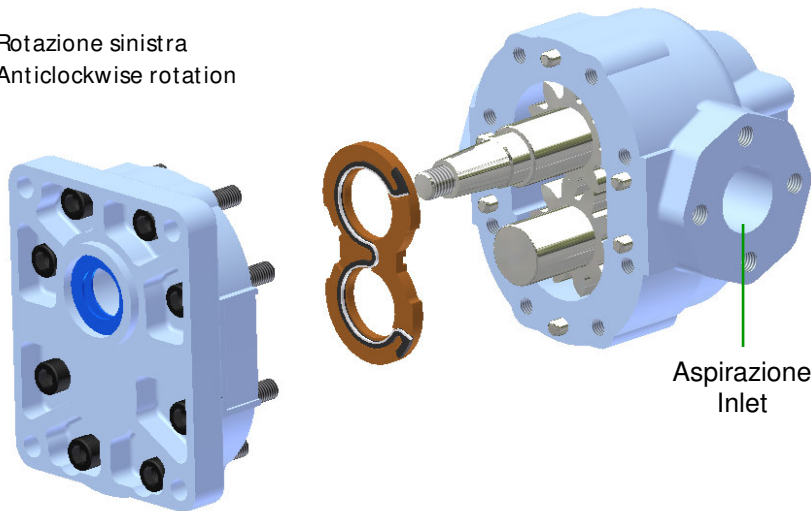

Il senso di rotazione, è indicato con una freccia sul corpo della pompa.  
*An arrow on the housing of the pump indicates the rotation.*

- Svitare le viti di fissaggio.
- Rimuovere la flangia tenendo premuto l'ingranaggio conduttore.
- Rimuovere contemporaneamente l'ingranaggio conduttore e il rasamento superiore mantenendo premuto l'ingranaggio condotto.
- Estrarre l'ingranaggio condotto tenendo fermo il rasamento inferiore, nel caso aiutarsi con una barretta NON metallica.
- Rimontare i due ingranaggi con posizioni invertite (vedi schema sopra).
- Rimontare il rasamento superiore facendo attenzione a NON invertirne la posizione.
- Cambiare di posizione al grano situato sulla faccia interna della flangia.
- Rimontare la flangia utilizzando per le viti una coppia di serraggio di 60-65 Nm.

- *Unscrew the clamping bolts.*
- *Remove the flange holding down the drive gear.*
- *Remove the drive gear and the bushing block holding down the idle gear.*
- *Remove the idle gear keeping down the rear bushing block with a no-metallic bar.*
- *Reverse the position of the two gears (see picture above)*
- *Replace the bushing block without rotate or changing position.*
- *Changing position of the grub screw on the flange (see picture above)*
- *Reverse the flange and retighten the bolts to a torque rating between 44-48 ft/lbs*



**DIMENSIONI CORPO W3**  
**HOLDING W3 DIMENSIONS**

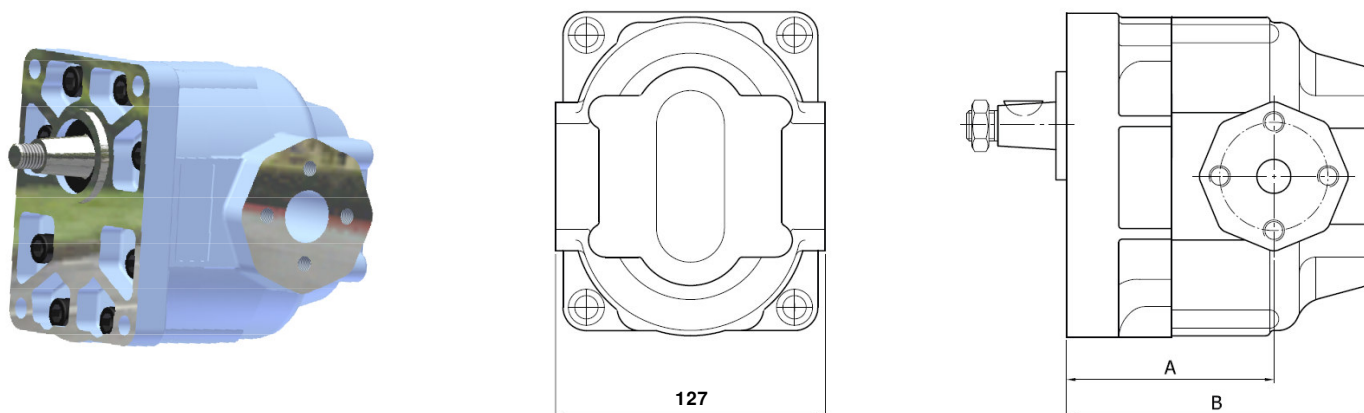

Tipo - Type		15	20	25	30	35	40	45	50	55	60	64	70	80
A	mm	70	76	76	79	82	82	85	85	85	89	89	90	95
B	mm	115	120	127	127	127	127	127	127	127	132	132	132	132

**DIMENSIONI CORPO W3L**  
**HOLDING W3L DIMENSIONS**

**Bocche posteriori**  
**Rear ports**

CODICE/CODE  
**J**

**Bocche laterali**  
**Lateral ports**

CODICE/CODE  
**X**

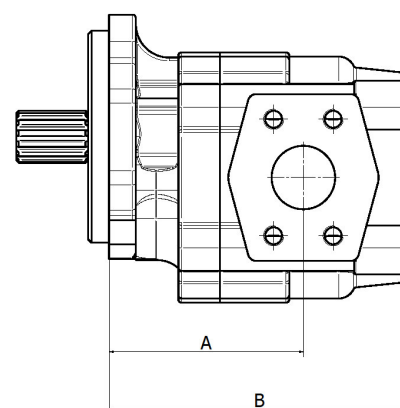
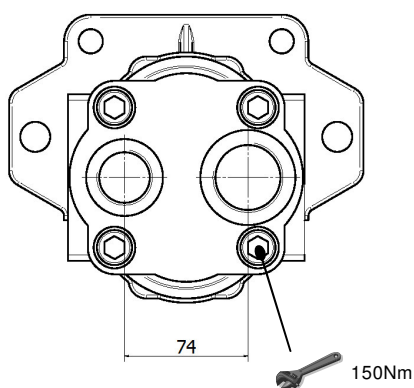
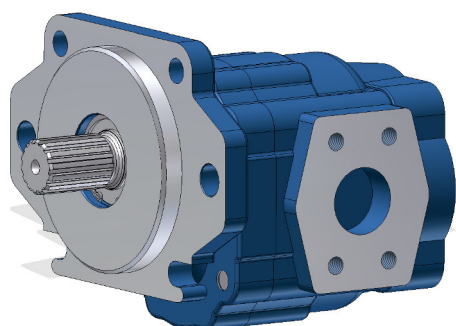

Tipo - Type		20	25	30	35	40	45	50	55	60	64	70	80	90
A	mm	103	106	110	112	108	110	114	116	105	107	111	116	116
B	mm	142	145	149	152	156	158	162	165	168	170	174	180	180

**FLANGE**  
**FLANGES**

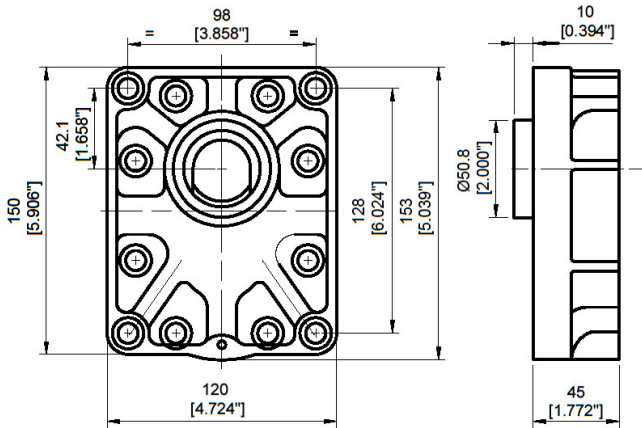

<b>CODICE</b> <i>CODE</i>	<b>A</b>	<b>0</b>
------------------------------	----------	----------

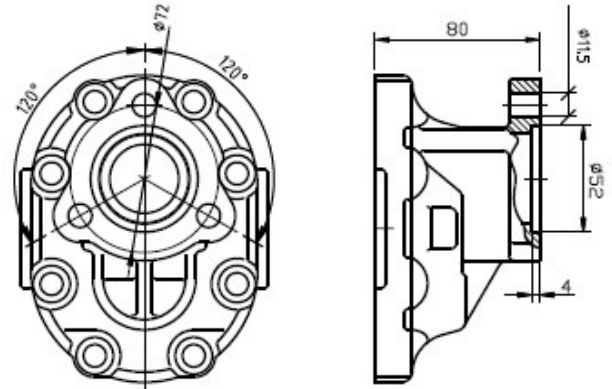

<b>CODICE</b> <i>CODE</i>	<b>N</b>	<b>7</b>
------------------------------	----------	----------

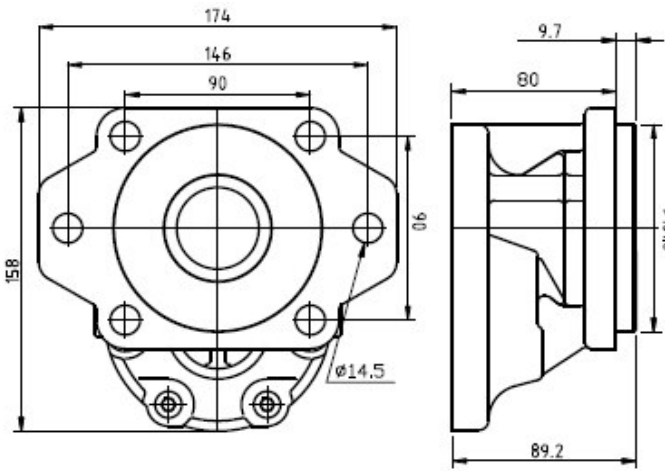

<b>CODICE</b> <i>CODE</i>	<b>B</b>	<b>3</b>
------------------------------	----------	----------

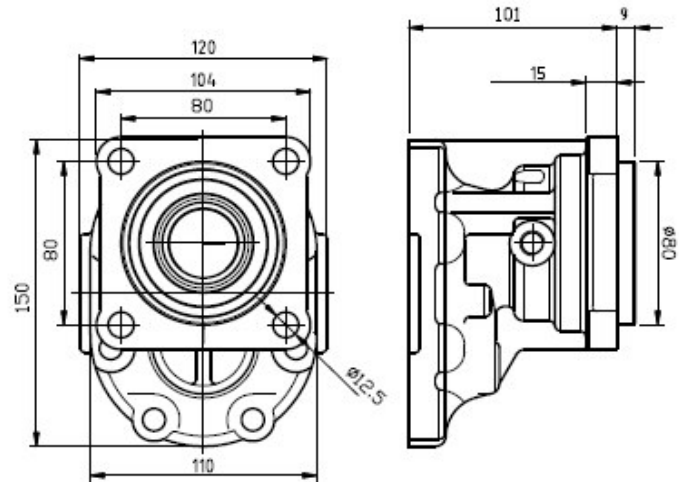

<b>CODICE</b> <i>CODE</i>	<b>I</b>	<b>4</b>
------------------------------	----------	----------

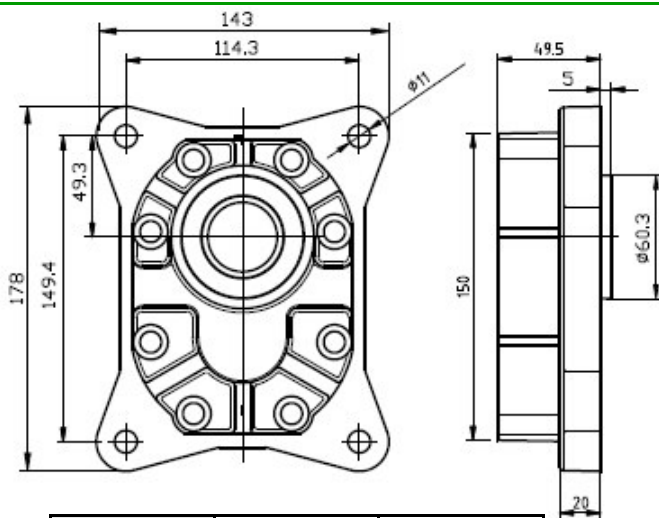

<b>CODICE</b> <i>CODE</i>	<b>D</b>	<b>5</b>
------------------------------	----------	----------

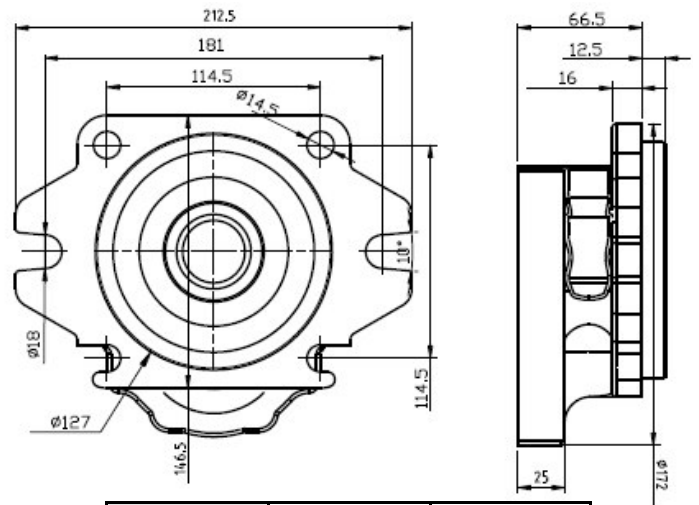

<b>CODICE</b> <i>CODE</i>	<b>C</b>	<b>6</b>
------------------------------	----------	----------

**FLANGE**  
**FLANGES**

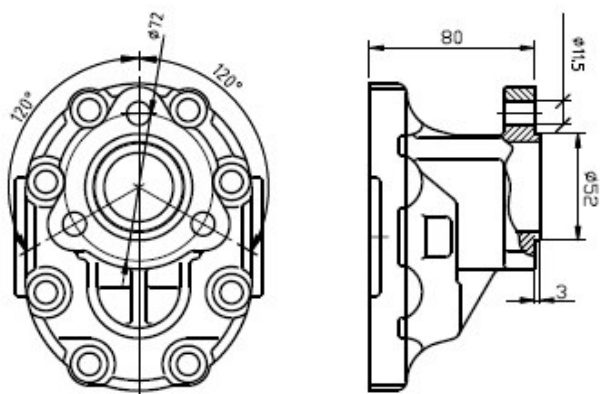

<b>CODICE</b> <i>CODE</i>	<b>N</b>	<b>8</b>
------------------------------	----------	----------

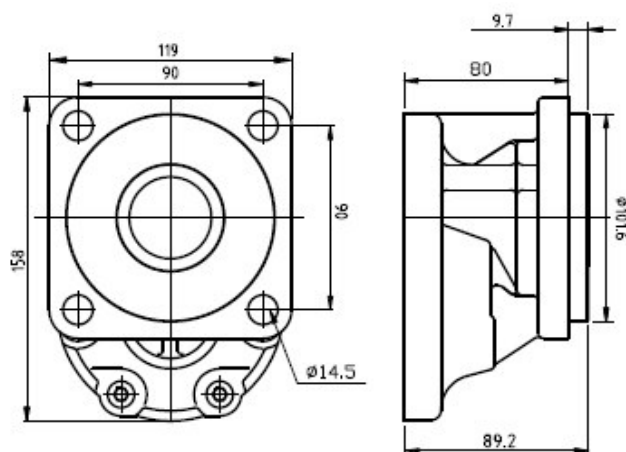

<b>CODICE</b> <i>CODE</i>	<b>L</b>	<b>3</b>
------------------------------	----------	----------

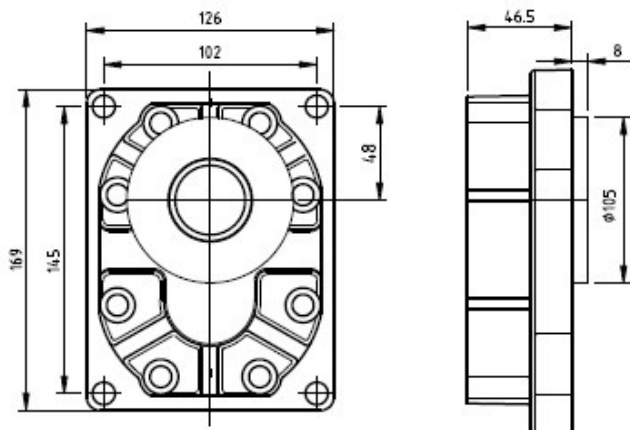

<b>CODICE</b> <i>CODE</i>	<b>G</b>	<b>4</b>
------------------------------	----------	----------

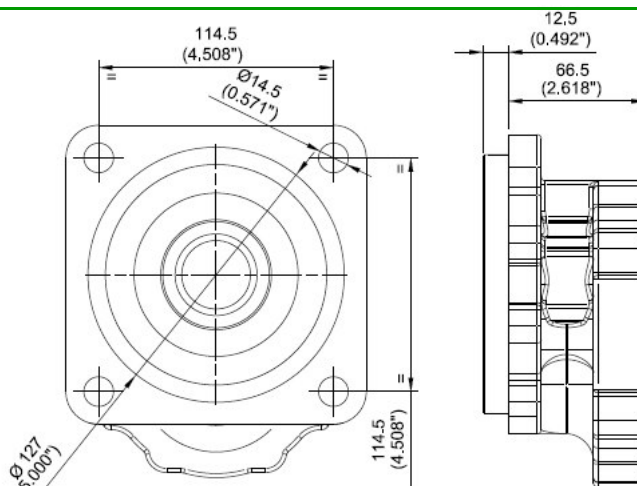

<b>CODICE</b> <i>CODE</i>	<b>E</b>	<b>6</b>
------------------------------	----------	----------

**ALBERI**  
**SHAFTS**

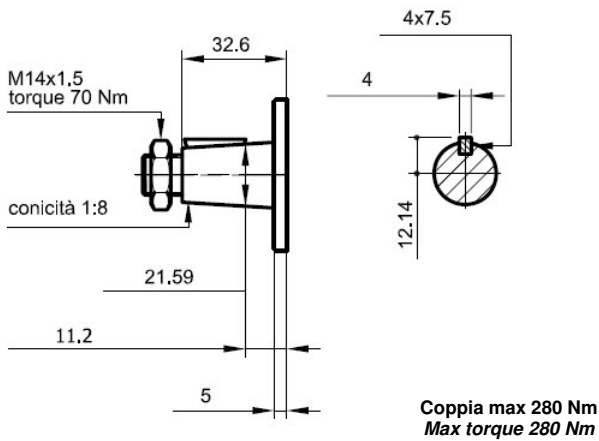

CODICE / CODE	C	
PER FLANGIA / FOR FLANGE	A	0

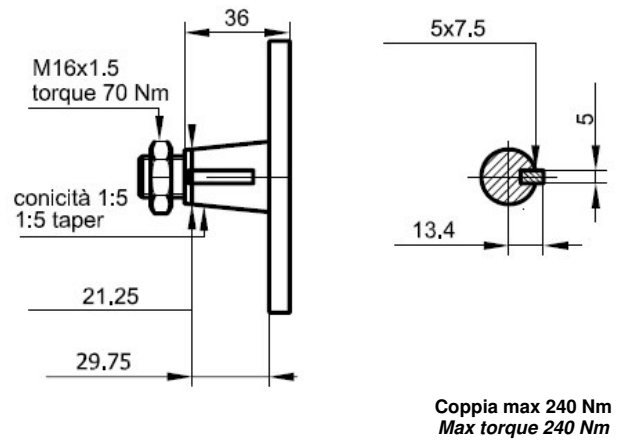

CODICE / CODE	A	
PER FLANGIA / FOR FLANGE	G	4

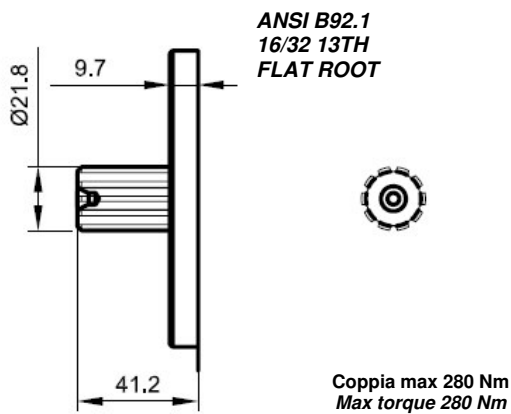

CODICE / CODE	B	
PER FLANGIA / FOR FLANGE	L	3
	B	3

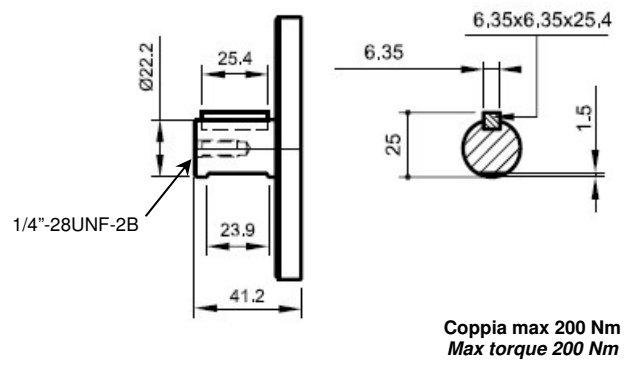

CODICE / CODE	L	
PER FLANGIA / FOR FLANGE	L	3
	B	3

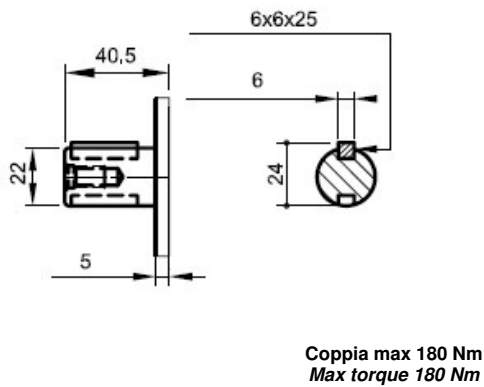

CODICE / CODE	Q	
PER FLANGIA / FOR FLANGE	A	0
	D	5

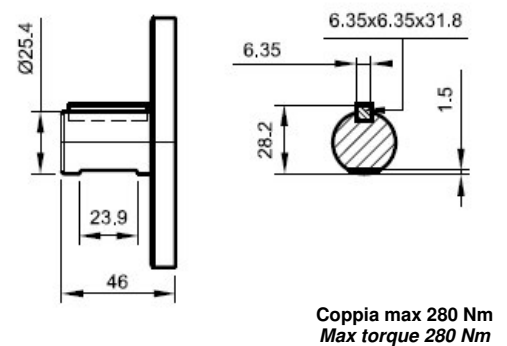

CODICE / CODE	D	
PER FLANGIA / FOR FLANGE	L	3
	B	3

**ALBERI**  
**SHAFTS**

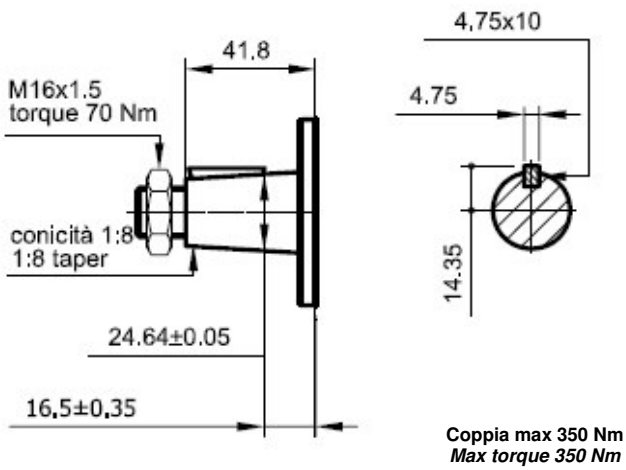

CODICE / CODE	E	
PER FLANGIA / FOR FLANGE	D	5

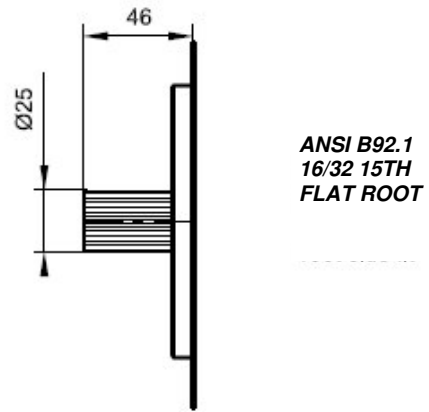

Coppia max 400 Nm  
Max torque 400 Nm

CODICE / CODE	S	
PER FLANGIA / FOR FLANGE	L	3
	B	3

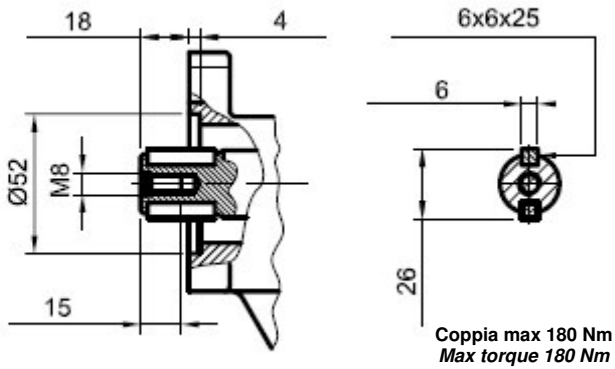

CODICE / CODE	N	
PER FLANGIA / FOR FLANGE	N	7

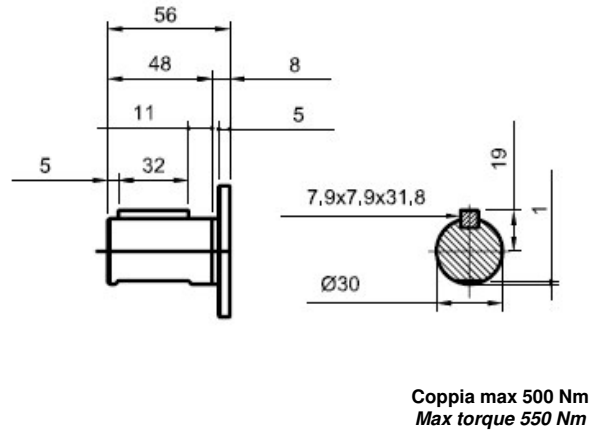

CODICE / CODE	G	
PER FLANGIA / FOR FLANGE	D	5

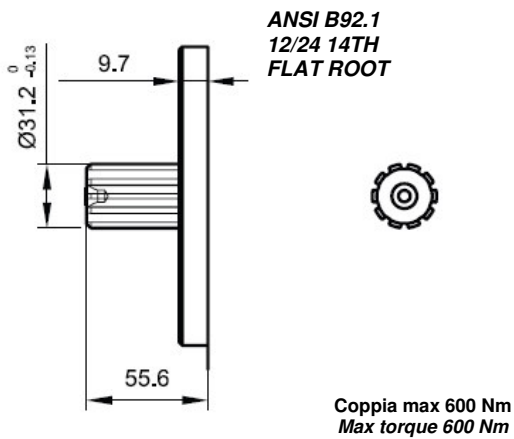

CODICE / CODE	K	
PER FLANGIA / FOR FLANGE	C	6
	E	6

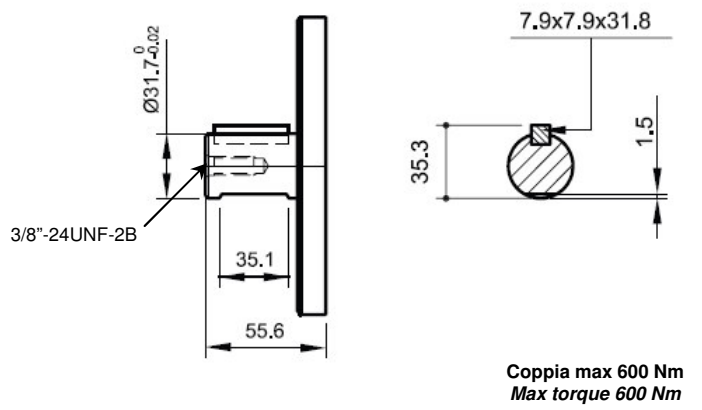

CODICE / CODE	P	
PER FLANGIA / FOR FLANGE	C	6
	E	6

**ALBERI**  
**SHAFTS**

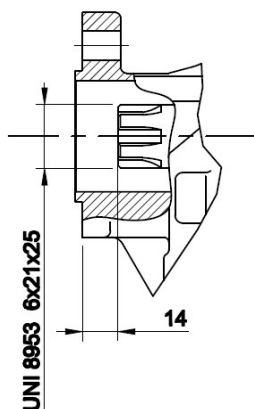

Coppia max 280 Nm  
Max torque 280 Nm

CODICE / CODE	F	
PER FLANGIA / FOR FLANGE	N	8

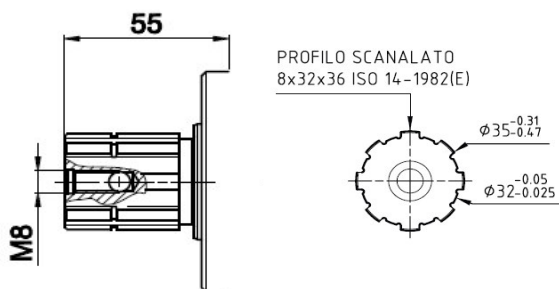

Coppia max 280 Nm  
Max torque 280 Nm

CODICE / CODE	H	
PER FLANGIA / FOR FLANGE	I	4

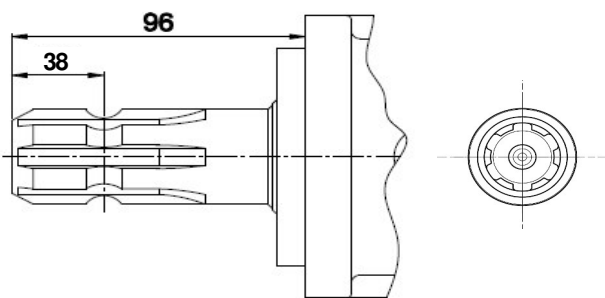

1"-3/8 DIN 9611 -Z6

Coppia max 280 Nm  
Max torque 280 Nm

CODICE / CODE	M	
PER FLANGIA / FOR FLANGE	I	4

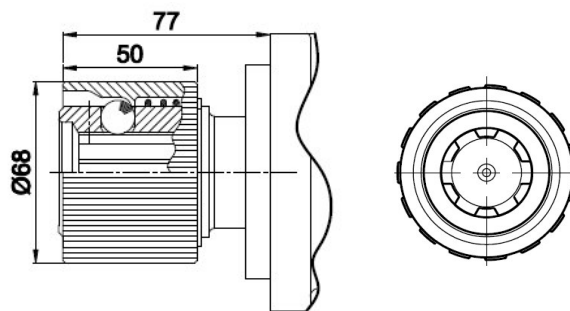

1"-3/8 DIN 9611 -Z6

Coppia max 280 Nm  
Max torque 280 Nm

CODICE / CODE	R	
PER FLANGIA / FOR FLANGE	I	4

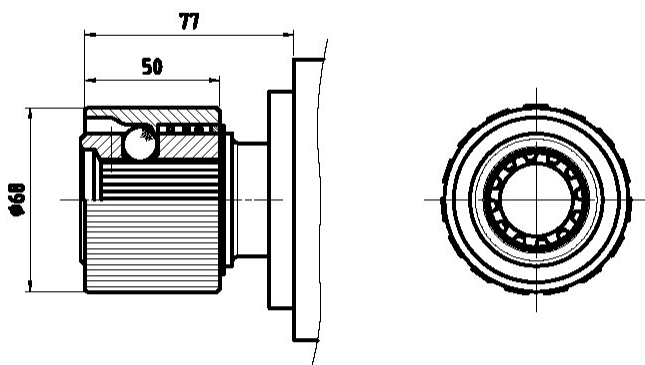

1"-3/8 DIN 9611 -Z21

Coppia max 280 Nm  
Max torque 280 Nm

CODICE / CODE	U	
PER FLANGIA / FOR FLANGE	I	4

**BOCCHIE DI ASPIRAZIONE EM ANDATA**  
**INLET AND OUTLET PORTS**

**XX** STANDARD

**XX** SU ORDINAZIONE / ON DEMAND

**□** NON DISPONIBILI / NOT AVAILABLE

	X	Y	Z
<b>A</b>	19	40	M8 18
<b>B</b>	27	51	M10 18
<b>C</b>	33	62	M12 18

		OUT		
IN		A	B	C
	<b>A</b>	49		
	<b>B</b>	48	46	
	<b>C</b>		47	45

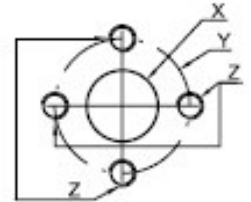

	X	Y	Z
<b>A</b>	19	40	M8 18
<b>B</b>	27	51	M10 18

		OUT	
IN		A	B
	<b>A</b>	50	
	<b>B</b>	51	52

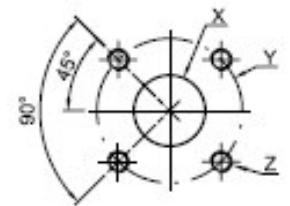

	X	Y	Z	J
<b>A</b>	12.5	38.1	17.5	5/16-18UNC-2B
<b>B</b>	19	47.6	22.2	3/8-16UNC-2B
<b>C</b>	25.4	52.4	26.2	
<b>D</b>	30.5	58.7	30.2	7/16-14UNC-2B
<b>E</b>	39.3	69.8	35.7	1/2-13UNC-2B
<b>F</b>	51	77.8	42.9	

		OUT					
IN		A	B	C	D	E	F
	<b>A</b>	53					
	<b>B</b>	54	55				
	<b>C</b>		56	57			
	<b>D</b>			58	59		
	<b>E</b>				60	61	
	<b>F</b>					62	63

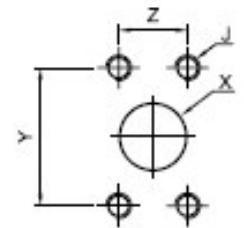

Disponibile con corpo WL  
 Available only with WL body

	X	Y	Z	DIMENSIONE NOMINALE
<b>A</b>	1" G	22	27	1
<b>B</b>	1" 1/4 G	22	33	1-1/4
<b>C</b>	1" 1/2 G	24	38	1-1/2

		OUT		
IN		A	B	C
	<b>A</b>	64		
	<b>B</b>	65	66	
	<b>C</b>		67	68

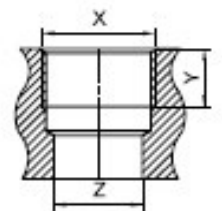

	DIMENSIONE NOMINALE	X	Y	Z	J
<b>A</b>	3/4"	1-1/16-12UN-2B	42	0.5	24.5
<b>B</b>	1"	1-5/16-12UN-2B	49	0.5	30.5
<b>C</b>	1" -1/4	15/8-12UN-2B	58	0.5	39
<b>D</b>	1" -1/2	1-7/8-12UN-2B	65	0.5	45

		OUT			
IN		A	B	C	D
	<b>A</b>	69			
	<b>B</b>	70	71		
	<b>C</b>		72	73	
	<b>D</b>			74	75

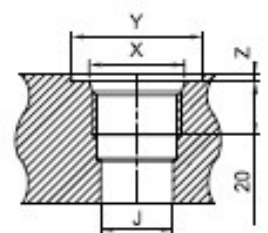

**BOCCHEDI ASPIRAZIONE EM ANDATA**  
***INLET AND OUTLET PORTS***

	X	Y	Z	J
<b>A</b>	12.5	38.1	17.5	M10
<b>B</b>	19	47.6	22.2	M10
<b>C</b>	25.4	52.4	26.2	M10
<b>D</b>	30.5	58.7	30.2	M10
<b>E</b>	39.3	69.8	35.7	M12
<b>F</b>	51	77.8	42.9	M12

		OUT					
IN		A	B	C	D	E	F
	<b>A</b>	76					
	<b>B</b>	77	78				
	<b>C</b>		79	80			
	<b>D</b>			81	82		
	<b>E</b>				83	84	
	<b>F</b>					85	86

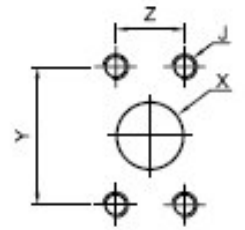

Disponibile con corpo WL  
 Available only with WL body

**CODICE BOCCHES STANDARD DISPONIBILI IN RELAZIONE ALLE CILINDRATE**  
***STANDARD PORT CODES AVAILABLE IN RELATION OF CAPACITY***

86													
85													
84													
83													
82													
81													
80													
79													
78													
77													
76													
75													
74													
73													
72													
71													
70													
69													
68													
67													
66													
65													
64													
63													
62													
61													
60													
59													
58													
57													
56													
55													
54													
53													
52													
51													
50													
49													
48													
47													
46													
45													
	20	25	30	35	40	45	50	55	60	64	70	80	90



**SUPPORTI INTEGRATI**  
**INBOARD BEARINGS**

**TIPO 1 - TYPE 1**

Supporto integrato con cuscinetto singolo

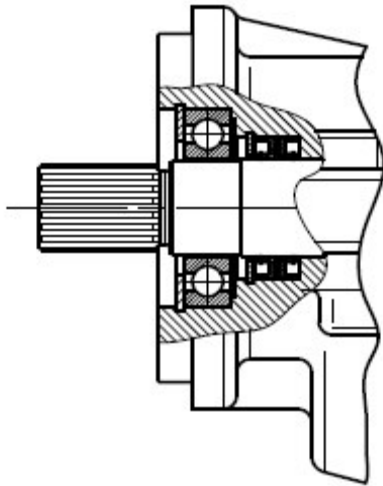

Versione adatta per impieghi con limitati carichi radiali e in assenza di carichi assiali

*Application made to support radial load and without axial*

Disponibile per flange B3 - L3 - G6 - E6.  
Available for flanges type B3 - L3 - G6 - E6.

Disponibile per alberi B - L - D - S - K - P - H.

**TIPO 2 - TYPE 2**

Supporto integrato con doppio cuscinetto a rulli conici

*Integrated bearing support with double tapered roller bearings*

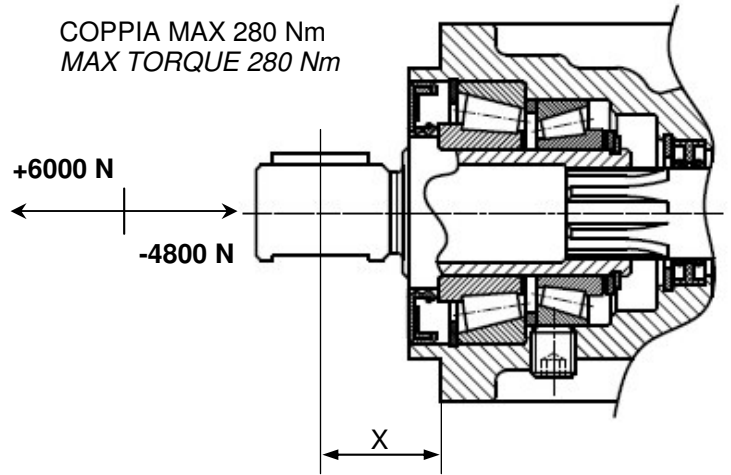

Versione adatta per impieghi con carichi radiali e assiali

*Application made to support axial and radial load.*

Disponibile per flangia I4  
Available for flange type I4

Disponibile per alberi S - K - P - H - M - R.  
Available for shafts type S - K - P - H - M - R.

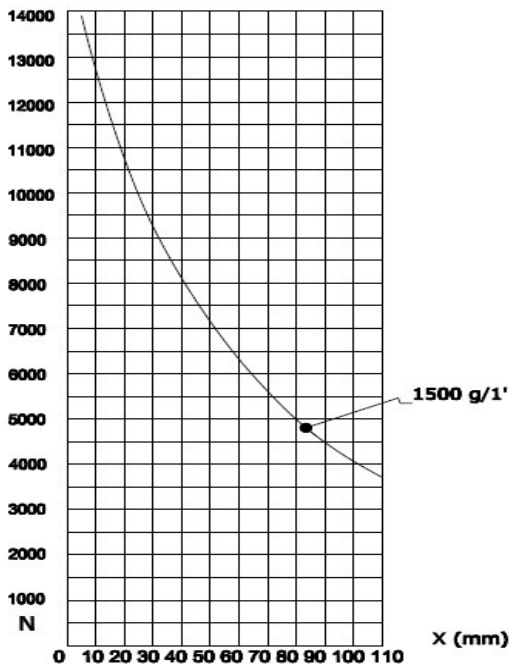

**DATI DI BASE PER STESURA GRAFICO**

- Durata a fatica corretta 1000 h
- Grasso VG 100
- Temperatura 70°C
- Affidabilità 90%
- Grado di contaminazione medio 60µ

IL VALORE DEI CARICHI E' INFLUENZATO DALLE CONDIZIONI DI FUNZIONAMENTO

**LOAD DIAGRAM**

- Rating fatigue life 1000 h
- Grease type VG-46
- Temperature 70°C
- Trust 90%
- Contamination 60 µ

LOAD VALUE IS DUE TO WORKING CONDITIONS

# ISTRUZIONI PER L'ORDINAZIONE DI UNITA' SINGOLE W3

## HOW TO ORDER W3 SINGLE UNITS

	1	2	3	4	5	6	7	8	9	10	11	12	13	
<b>03</b>	<b>0</b>	<b>W0</b>	<b>M</b>	<b>A</b>	<b>55</b>	<b>C</b>	<b>0</b>	<b>48</b>	<b>X</b>	<b>S</b>	<b>1</b>	<b>B</b>	<b>VR</b>	<b>75</b>

<b>1</b>	RASAMENTI / BUSHING BLOCK	CODICE / CODE
	ALLUMINIO / ALLOY	<b>2</b>
	BRONZO / BRONZE	<b>0</b>

<b>2</b>	TIPO DI UNITA' / UNIT TYPE	CODICE / CODE
	POMPA / PUMP	-
	MOTORE / MOTOR	<b>M</b>

<b>3 - 6</b>	FLANGIA / FLANGE (PAG. 10-11)	CODICE / CODE
	EUROPEA GR. 3 / EUROPEAN GR. 3	<b>A - 0</b>
	ITALIANA / ITALIAN	<b>N - 7</b>
	AMERICANA SAE B / AMERICAN SAE B	<b>B - 3</b>
	ISO / ISO	<b>I - 4</b>
	EUROPEA GR. 3,5 / EUROPEAN GR. 3,5	<b>D - 5</b>
	AMERICANA SAE C / AMERICAN SAE C	<b>C - 6</b>
	AMERICANA SAE C / AMERICAN SAE C	<b>E - 6</b>
	ITALIANA / ITALIAN	<b>N - 8</b>
	AMERICANA SAE B / AMERICAN SAE B	<b>L - 3</b>
	TEDESCA / GERMAN	<b>C - 4</b>

<b>4</b>	CILINDRATA / CAPACITY cm <sup>3</sup>	CODICE / CODE
	15.5	<b>15</b>
	19.9	<b>20</b>
	24.9	<b>25</b>
	29.9	<b>30</b>
	34.3	<b>35</b>
	40.5	<b>40</b>
	45.2	<b>45</b>
	49.9	<b>50</b>
	54.5	<b>55</b>
	60	<b>60</b>
	63.9	<b>64</b>
	70	<b>70</b>
	78.7	<b>80</b>
	89.6	<b>90</b>

<b>5</b>	ALBERO / SHAFT (PAG. 12-13-14)	CODICE / CODE
	CONICO 1:8 / TAPERED 1:8	<b>C</b>
	CONICO 1:5 / TAPERED 1:5	<b>A</b>
	ANSI B92.1 13TH 16/32 DP	<b>B</b>
	CILINDRICO Ø22.22 / STRAIGHT Ø22.22	<b>L</b>
	CILINDRICO Ø22 / STRAIGHT Ø22	<b>Q</b>
	CILINDRICO Ø25.4 / STRAIGHT Ø25.4	<b>D</b>
	CONICO 1:8 / TAPERED 1:8	<b>E</b>
	ANSI B92.1 15TH 16/32 DP	<b>S</b>
	ISO 14 8x32x36	<b>H</b>

	CILINDRICO Ø22 / STRAIGHT Ø22	<b>N</b>
	CILINDRICO Ø30 / STRAIGHT Ø30	<b>G</b>
	ANSI B92.1 14TH 12/24 DP	<b>K</b>
	CILINDRICO Ø31.7/ STRAIGHT Ø31.7	<b>P</b>
	UNI 8953 6x21x25	<b>F</b>
	1" 3/8 DIN 9611 MASCHIO / MALE	<b>M</b>
	1" 3/8 DIN 9611 FEMMINA / FEMALE	<b>R</b>

<b>7</b>	BOCCHIE / PORTS	CODICE / CODE
	VEDI TABELLA PAG. 16 / SEE TABLE AT PAGE 16	

<b>8</b>	POSIZIONE BOCCHIE / PORTS POSITION	CODICE / CODE
	LATERALE / LATERAL	<b>X</b>
	POSTERIORE / REAR	<b>J</b>

<b>9</b>	ROTAZIONE / ROTATION	CODICE / CODE
	DESTRO / RIGHT	<b>D</b>
	SINISTRO / LEFT	<b>S</b>
	BIDIRECTIONAL WITH INTERNAL DRAIN	<b>Y</b>
	BIDIRECTIONAL WITH EXTERNAL DRAIN	<b>R</b>
	BIDIRECTIONAL WITH LATERAL DRAIN	<b>R1</b>

<b>10</b>	SUPPORTI / SUPPORT (PAG.17)	CODICE / CODE
	SENZA / WITHOUT	<b>0</b>
	TIPO 1 / TYPE 1	<b>1</b>
	TIPO 2 / TYPE 2	<b>2</b>

<b>11</b>	PARAOILIO / SHAFT SEAL (PAG.7)	CODICE / CODE
	STANDARD / STANDARD	<b>N</b>
	5 BAR NBR / 5 BAR NBR	<b>R</b>
	5 BAR VITON / 5 BAR VITON	<b>RV</b>
	DOPPIO M IM NBR / DOUBLE SEAL NBR	<b>N2</b>
	DOPPIO M IM VITON / DOUBLE SEAL VITON	<b>V2</b>
	VARI SEAL NBR / VARI SEAL NBR	<b>B</b>
	25 BAR NBR / 25 BAR NBR	<b>BN</b>
	25 BAR VITON / 25 BAR VITON	<b>BV</b>

<b>12</b>	VALVOLA DI MASSIMA / RELIEF VALVE	CODICE / CODE
	SENZA / WITHOUT	-
	TARATURA REGOLABILE / ADJUST. CALIBRATION	<b>VR</b>
	TARATURA FISSA / FIXED CALIBRATION	<b>VF</b>

<b>13</b>	VALORI TARATURA VALVOLA	CODICE / CODE
	50 - 75 - 100 - 125 - 150 - 200 - 250 - 300 - 330	<b>75</b>

**KIT DI MONTAGGIO POM PE MULTIPLE W3**  
**ASSEMBLING KITS FOR MULTIPLE PUMPS W3**

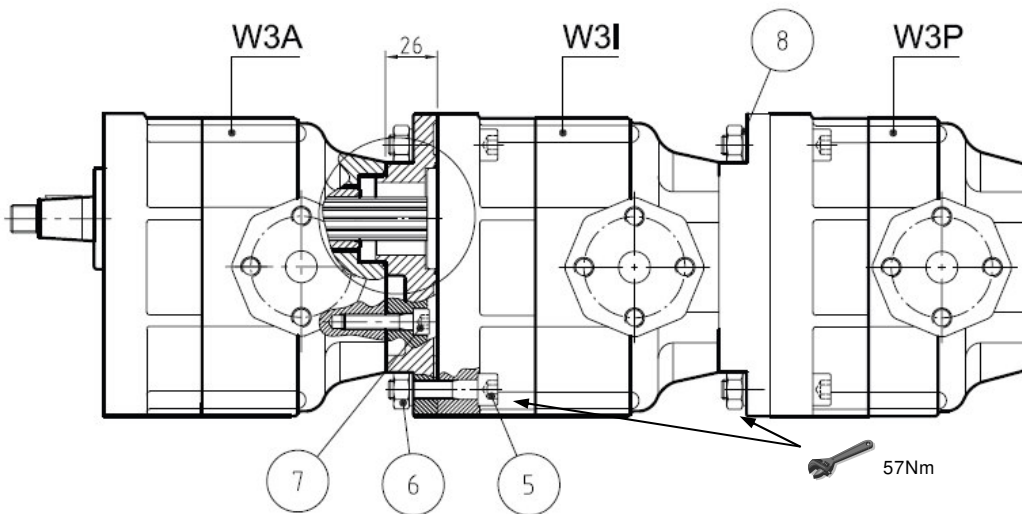
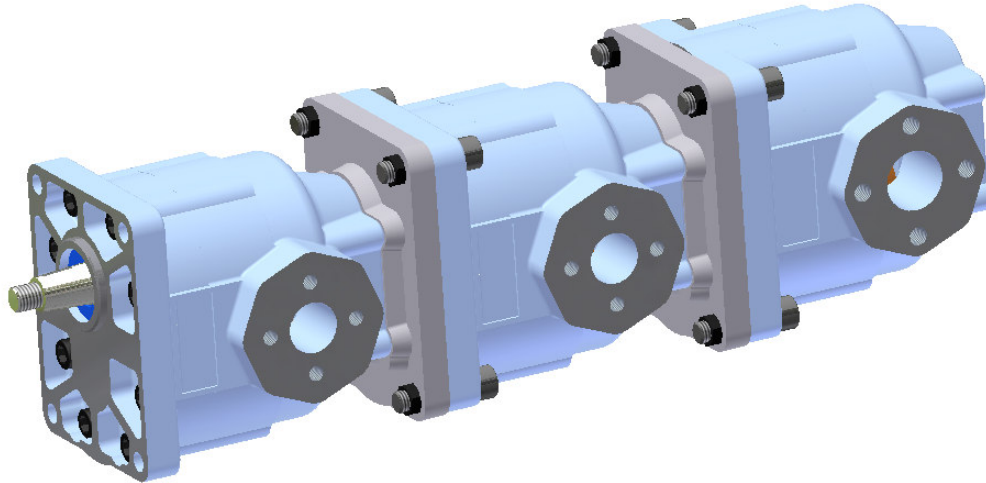

KIT DI MONTAGGIO ASSEMBLING KIT		Cod. K3000028
Ref	PARTI	
1	OR 3200 / O-Ring 3200	
2	OR 2162 / O-Ring 2162	
3	Plastra di collegamento / Connection plate	
4	Mozzo DIN 5482 / Coupling DIN 5482	
5	TCE M10x55 UNI 5931 / TCE M10x55 UNI 5931	
6	Dado M10 / Stud nut M10	
7	TCE M8x25 UNI 5931 / TCE M8x25 UNI 5931	
8	Rondella 10.5x16x2 / Washer 10.5x16x2	

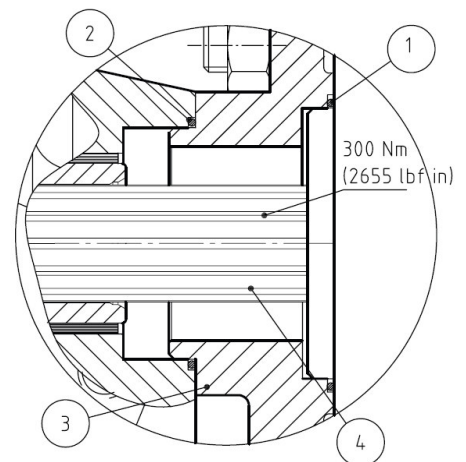

# ISTRUZIONI PER L'ORDINAZIONE DI POMPE MULTIPLE W3

## HOW TO ORDER W3 MULTIPLE PUMP

1	2	3	4	5	6	7	8	9					
03	0	W0	A	A	55	C	0	48	X	S	1	B	FRONT PUMP
1	3	6	7										
03	0	W0	I	A	55	0	0	48	X	S	0		MIDDLE PUMP
1	3	6	7										
03	0	W0	P	A	55	0	0	48	X	S	0		REAR PUMP

<b>1</b>	RASAMENTI / BUSHING BLOCK	CODICE / CODE
	ALLUMINIO / ALLOY	2
	BRONZO / BRONZE	0

<b>2 - 5</b>	FLANGIA / FLANGE (PAG. 10-11)	CODICE / CODE
	EUROPEA GR. 3 / EUROPEAN GR. 3	A - 1
	ITALIANA / ITALIAN	N - 7
	AMERICANA SAE B / AMERICAN SAE B	B - 3
	ISO / ISO	I - 4
	EUROPEA GR. 3,5 / EUROPEAN GR. 3,5	D - 5
	AMERICANA SAE C / AMERICAN SAE C	C - 6
	AMERICANA SAE C / AMERICAN SAE C	E - 6
	ITALIANA / ITALIAN	N - 8
	AMERICANA SAE B / AMERICAN SAE B	L - 3
	TEDESCA / GERMAN	C - 4

<b>3</b>	CILINDRATA / CAPACITY cm <sup>3</sup>	CODICE / CODE
	15.5	15
	19.9	20
	24.9	25
	29.9	30
	34.3	35
	40.5	40
	45.2	45
	49.9	50
	54.5	55
	60	60
	63.9	64
	70	70
	78.7	80
	89.6	90

<b>4</b>	ALBERO / SHAFT (PAG. 12-13-14)	CODICE / CODE
	CONICO 1:8 / TAPERED 1:8	C
	CONICO 1:5 / TAPERED 1:5	A
	ANSI B92.1 13TH 16/32 DP	B
	CILINDRICO Ø22.22 / STRAIGHT Ø22.22	L

	CILINDRICO Ø22 / STRAIGHT Ø22	Q
	CILINDRICO Ø25.4 / STRAIGHT Ø25.4	D
	CONICO 1:8 / TAPERED 1:8	E
	ANSI B92.1 15TH 16/32 DP	S
	ISO 14 8x32x36	H
	CILINDRICO Ø22 / STRAIGHT Ø22	N
	CILINDRICO Ø30 / STRAIGHT Ø30	G
	ANSI B92.1 14TH 12/24 DP	K
	CILINDRICO Ø31.7 / STRAIGHT Ø31.7	P
	UNI 8953 6x21x25	F
	1" 3/8 DIN 9611 MASCHIO / MALE	M
	1" 3/8 DIN 9611 FEMMINA / FEMALE	R

<b>6</b>	BOCCHE / PORTS	CODICE / CODE
	VEDI TABELLA PAG. 16 / SEE TABLE AT PAGE 16	

<b>7</b>	ROTAZIONE / ROTATION	CODICE / CODE
	DESTRO / RIGHT	D
	SINISTRO / LEFT	S

<b>8</b>	SUPPORTI / SUPPORT (PAG. 17)	CODICE / CODE
	SENZA / WITHOUT	0
	TIPO 1 / TYPE 1	1
	TIPO 2 / TYPE 2	2

<b>9</b>	PARAOILIO / SHAFT SEAL (PAG.7)	CODICE / CODE
	STANDARD / STANDARD	N
	5 BAR NBR / 5 BAR NBR	R
	5 BAR VITON / 5 BAR VITON	RV
	DOPPIO MIM NBR / DOUBLE SEAL NBR	N2
	DOPPIO MIM VITON / DOUBLE SEAL VITON	V2
	VARISEAL NBR / VARISEAL NBR	B
	25 BAR NBR / 25 BAR NBR	BN
	25 BAR VITON / 25 BAR VITON	BV

**KIT DI MONTAGGIO POM PE MULTIPLE W3 - Z2**  
**ASSEMBLING KITS FOR MULTIPLE PUMPS W3 - Z2**

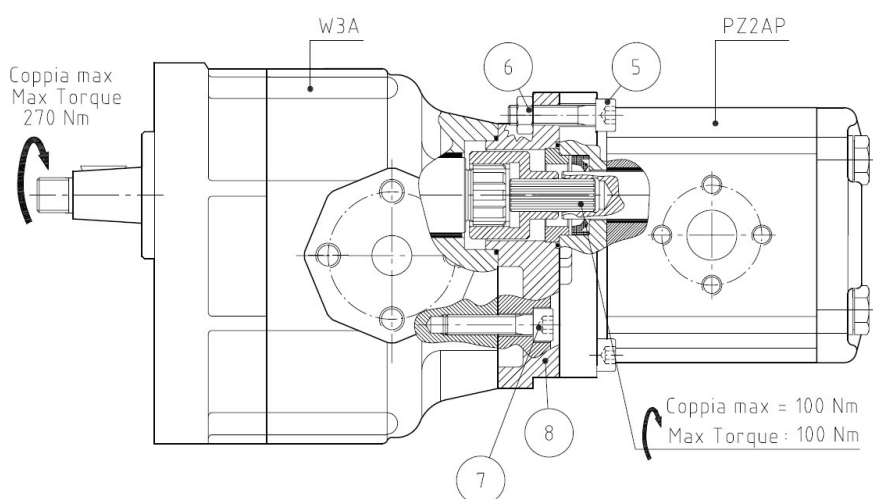
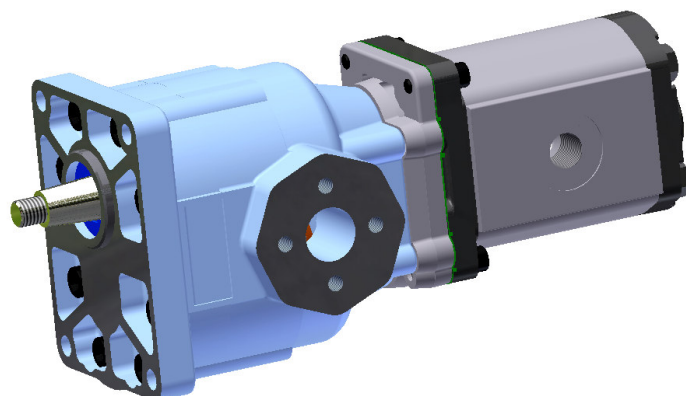

KIT DI MONTAGGIO ASSEMBLING KIT	
W3 + 02ZA	cod. K3000038
Ref	PARTI
1	OR2150 / O-Ring 2150
2	OR2162 / O-Ring 2162
3	Mozzo 25x21/Z=25 / Coupling 25x21/Z=25
4	Albero 25x21/Z=25 / Shaft 25x21/Z=25
5	TCE M8x35 UNI 5931 / TCE M8x35 UNI 5931
6	Dado M8 / Stud nut M8
7	TCE M8x35 UNI 5931 / TCE M8x35 UNI 5931
8	Piastra di collegamento / Connection plate
9	Bussola di centraggio / Pilot ring

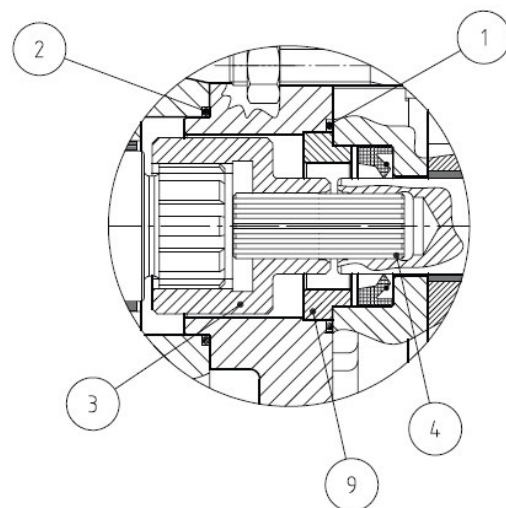

**KIT DI MONTAGGIO POM PE MULTIPLE W3 - Z1**  
**ASSEMBLING KITS FOR MULTIPLE PUMPS W3 - Z1**

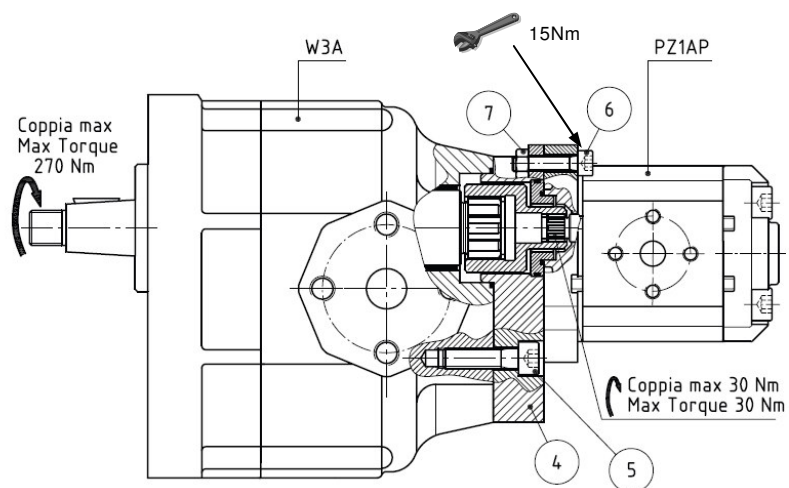
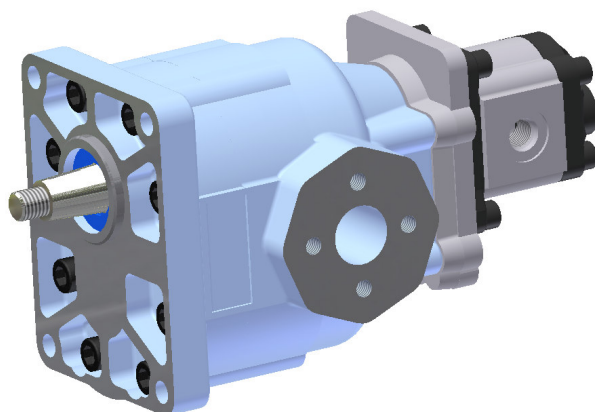

<b>KIT DI MONTAGGIO ASSEMBLING KIT</b>	
cod. K3000003	
Ref	PARTI
1	OR2100 / O-Ring 2100
2	OR2162 / O-Ring 2162
3	Mozzo 25x21-12x19 / Coupling 25x21-12/19
4	Piastra di collegamento / Connection plate
5	TCE M8x30 UNI 5931 / TCE M8x30 UNI 5931
6	TCE M6x25 UNI 5931 / TCE M6x25 UNI 5931
7	Dado M6 / Stud nut M6
8	OR2137 / O-Ring 2137
9	Bussola di centraggio / Pilot ring

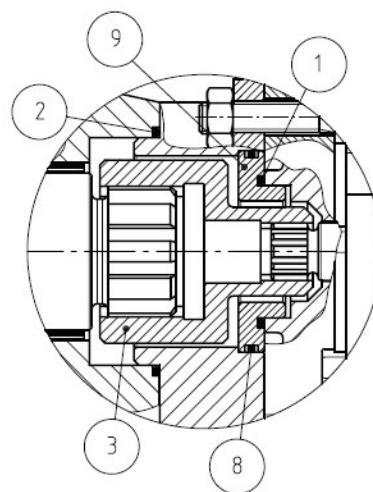

**DIMENSIONI POM PE MULTIPLE W3L**  
**OVERALL DIMENSIONS MULTIPLE PUMPS W3L**

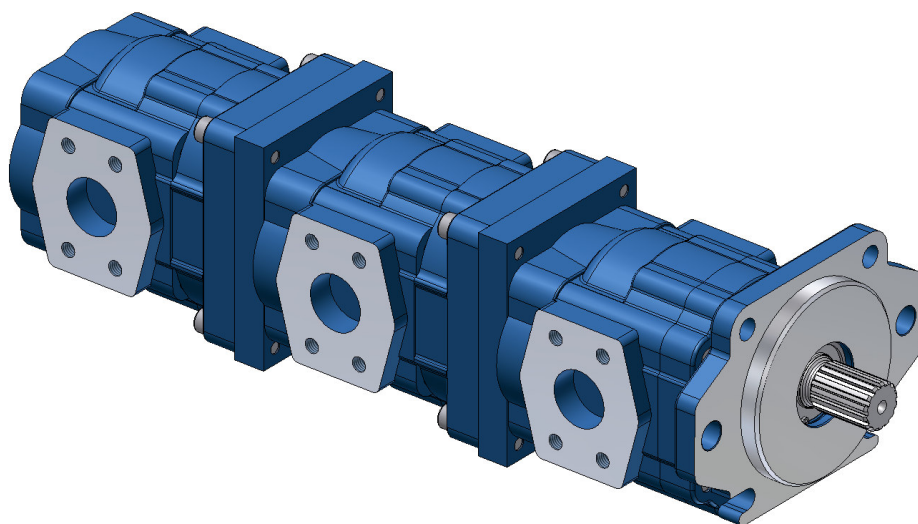

COPPIA MAX 300 Nm  
 MAX TORQUE 300 Nm

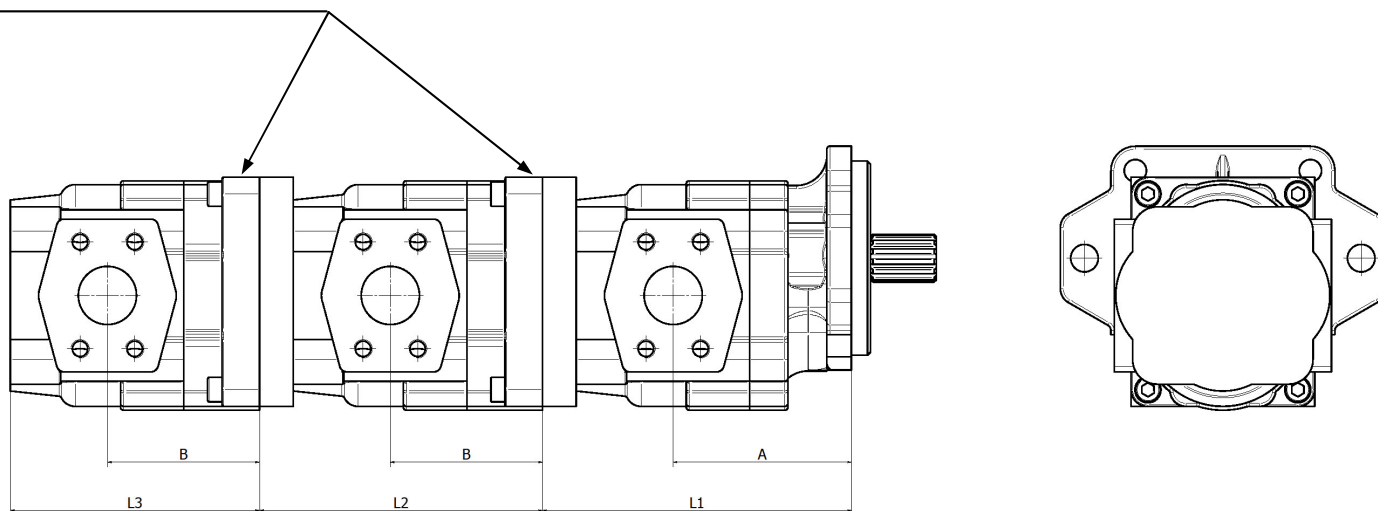

Tipo - Type		20	25	30	35	40	45	50	55	60	64	70	80	90
<b>A</b>	mm	104	107	110	113	108	111	114	117	105	107	111	117	117
<b>B</b>	mm	87	90	93	96	91	94	97	100	88	90	94	100	100
<b>L1</b>	mm	159	162	165	168	172	175	178	181	185	187	191	197	202
<b>L2</b>	mm	142	145	148	151	155	158	161	164	168	170	174	180	185
<b>L3</b>	mm	126	129	132	135	139	142	145	148	152	154	158	164	164

**DIMENSIONI POM PE MULTIPLE W3L CON ASPIRAZIONE COMUNE**  
**OVERALL DIMENSIONS MULTIPLE PUMPS W3L WITH COMMON INLET**

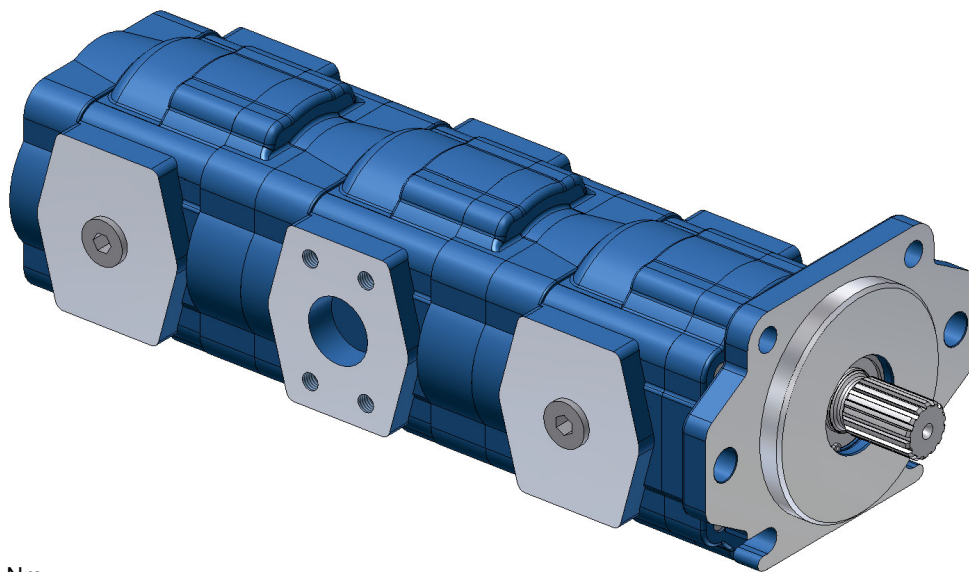

COPPIA MAX 300 Nm  
 MAX TORQUE 300 Nm

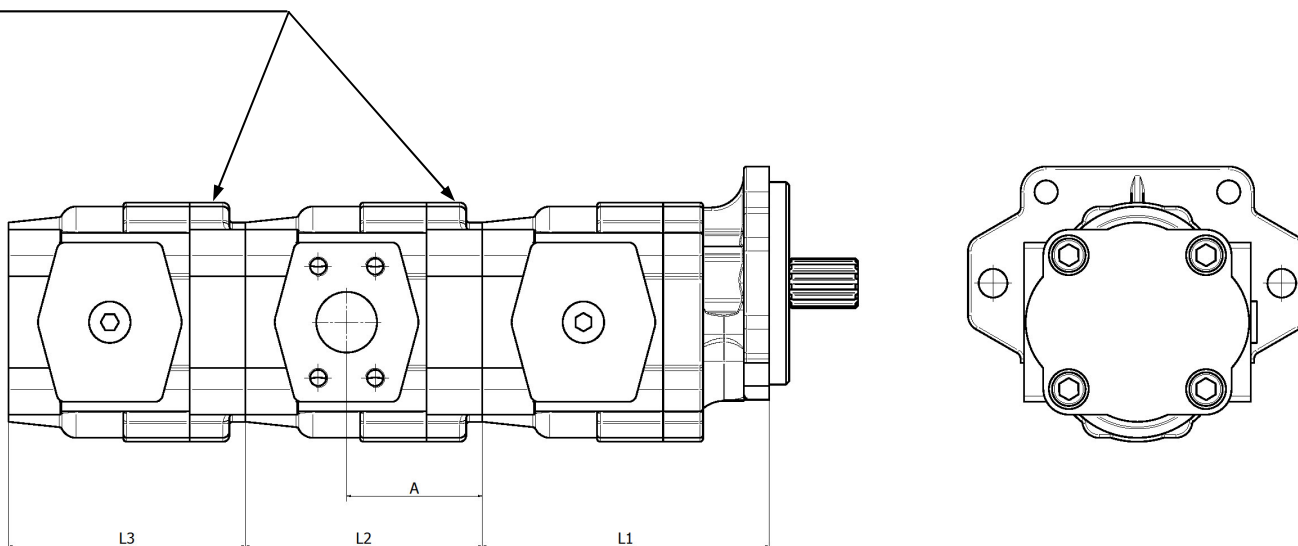

Tipo - Type		20	25	30	35	40	45	50	55	60	64	70	80	90
<b>A</b>	mm	72	75	78	81	76	79	82	85	73	75	79	85	85
<b>L1</b>	mm	137	140	143	146	150	153	156	159	163	165	169	175	180
<b>L2</b>	mm	106	109	112	115	119	122	125	128	132	134	138	144	149
<b>L3</b>	mm	111	114	117	120	124	127	130	133	137	139	143	149	149

Per maggiori informazioni contattare nostro ufficio tecnico  
 For more info contact our technical office



# ISTRUZIONI PER L'ORDINAZIONE DI POM PEM MULTIPLE WL3

## HOW TO ORDER WL3 MULTIPLE PUMP

	1	2	3	3	3	4	5	6	6	6	7	8	9	
03	0	WL	A	20*	20*	20*	E	0	70*	70*	70*	D	0	N

ESEMPIO PER POM PA A TRE STADI  
EXAMPLE FOR A PUMP WITH THREE STAGES

<b>1</b>	RASAMENTI / BUSHING BLOCK	CODICE / CODE
	ALLUMINIO / ALLOY	2
	BRONZO / BRONZE	0

<b>2 - 5</b>	FLANGIA / FLANGE (PAG. 10-11)	CODICE / CODE
	AMERICANA SAE B / AMERICAN SAE B	B - 3
	ISO / ISO	I - 4
	EUROPEA GR. 3,5 / EUROPEAN GR. 3,5	D - 5
	AMERICANA SAE C / AMERICAN SAE C	C - 6
	AMERICANA SAE C / AMERICAN SAE C	E - 6
	AMERICANA SAE B / AMERICAN SAE B	L - 3

<b>3</b>	CILINDRATA / CAPACITY cm <sup>3</sup>	CODICE / CODE
	19.9	20
	24.9	25
	29.9	30
	34.3	35
	40.5	40
	45.2	45
	49.9	50
	54.5	55
	60	60
	63.9	64
	70	70
	78.7	80
	89.6	90

<b>4</b>	ALBERO / SHAFT (PAG. 12-13-14)	CODICE / CODE
	ANSI B92.1 13TH 16/32 DP	B
	CILINDRICO Ø22.22 / STRAIGHT Ø22.22	L
	CILINDRICO Ø25.4 / STRAIGHT Ø25.4	D
	CONICO 1:8 / TAPERED 1:8	E
	ANSI B92.1 15TH 16/32 DP	S
	ISO 14 8x32x36	H

	CILINDRICO Ø30 / STRAIGHT Ø30	G
	ANSI B92.1 14TH 12/24 DP	K
	CILINDRICO Ø31.7 / STRAIGHT Ø31.7	P
	UNI 8953 6x21x25	F

<b>6</b>	BOCCHE / PORTS	CODICE / CODE
	VEDI TABELLA PAG. 16 / SEE TABLE AT PAGE 16	

<b>7</b>	ROTAZIONE / ROTATION	CODICE / CODE
	DESTRO / RIGHT	D
	SINISTRO / LEFT	S

<b>8</b>	SUPPORTI / SUPPORT (PAG. 17)	CODICE / CODE
	SENZA / WITHOUT	0
	TIPO 1 / TYPE 1	1

<b>9</b>	PARAOILIO / SHAFT SEAL (PAG. 7)	CODICE / CODE
	STANDARD / STANDARD	N
	5 BAR NBR / 5 BAR NBR	R
	5 BAR VITON / 5 BAR VITON	RV
	DOPPIO MIM NBR / DOUBLE SEAL NBR	N2
	DOPPIO MIM VITON / DOUBLE SEAL VITON	V2
	VARISEAL NBR / VARISEAL NBR	B
	25 BAR NBR / 25 BAR NBR	BN
	25 BAR VITON / 25 BAR VITON	BV

\* INSERIRE NEL CODICE IL VALORE PER OGNI POM PA DESIDERATA  
INSERT IN THE CODE THE VALUE FOR EACH PUMP EXPECTED



---

---

---

---

---

---

---

---

---

---

---

---

---

---

---

---

---

---

---

---

---

---

---

---

---

---

---

---

---

---

La Ronzio Oleodinamica si riserva di apportare in qualunque momento modifiche ai modelli descritti sia per ragioni di natura tecnica che commerciale. Riproduzione vietata.

*Ronzio Oleodinamica reserves the right to make change to the product described here in any time it deems fit in relation to technical or commercial requirements.*



**RONZIO**  
**OLEODINAMICA**

VIALE INDUSTRIA 37/39, 20010 BOFFALORA TICINO -MI-  
TEL. 02 9754057 FAX 02 97255070  
E-mail [sales@ronzio.com](mailto:sales@ronzio.com) - [www.ronzio.com](http://www.ronzio.com)