

ALUMINIUM PUMPS AND MOTORS **Z3 SERIES**

POMPE E MOTORI IN ALLUMINIO SERIE Z3

MADE IN ITALY



Ronzio Oleodinamica fu fondata nel 1950 da Dante Ronzio esperto in meccanica di precisione. La prima attività dell'azienda fu la lavorazione di pompe per motori diesel, seguita, qualche anno più tardi, dalla costruzione di pompe oleodinamiche ad ingranaggi, che presto divenne la produzione prevalente. La passione del fondatore per la meccanica fine ha lasciato nella Ronzio Oleodinamica un'impronta significativa; il motto dell'azienda è sempre stato quello di operare all'insegna della qualità e precisione, sia nell'impiego delle materie prime sia nel controllo del processo produttivo. Ronzio Oleodinamica produce ora pompe, motori e divisori di flusso che trovano impiego in molti settori industriali sia nel veicolo che negli impianti fissi, nelle macchine agricole, forestali e nel movimento terra. La struttura snella della nostra azienda e la nostra esperienza sono la risposta ai clienti che cercano in noi non solo un fornitore ma un partner nello sviluppo dei loro progetti. Il nostro sistema qualità è certificato da DNV dal 1998.

Ronzio Oleodinamica was established in 1950 by Mr. Dante Ronzio, fond of precision mechanics.

The company started its activity machining pumps for diesel motors. The passion of the founder for fine mechanics left an important mark in the company. The production of hydraulic gear pumps started some years later and became soon the main activity of the company.

Since the beginning Ronzio Oleodinamica has been focusing on quality and precision. Our company uses top quality components and the most advanced computerized machines, both in the production and in the testing process.

Ronzio Oleodinamica manufactures gear pumps, motors and flow dividers in aluminium and in cast iron for a wide range of industries including: constructions, forestry, agriculture, industrial vehicles, earth moving, industrial.

Today, our products are worldwide appreciated.

Our experience and our lean structure are suitable for customers who need a direct involvement of the supplier in their projects.

Our quality system has been certified by DNV since 1998.

Caratteristiche principali

- Coperchi in ghisa per elevate prestazioni.
- Possibilità di funzionare ad alte pressioni: fino a 280 bar di pressione massima in funzionamento continuo.
- Compensazione assiale per il recupero dei giochi
- Alto rendimento volumetrico: 95-97% medio.
- Ampia disponibilità di cilindrata: 20-25-30-35-40-45-50-55-60-64-70-80-90cm³/giro.
- Corpo in alluminio estruso.
- Progetto accurato del profilo del dente per avere una bassa rumorosità.
- Vasta gamma di flange, alberi e connessioni compatibili con i principali standard del mercato.
- Disponibilità di guarnizioni per alte temperature.
- Pompe e motori unidirezionali.
- Pompe e motori bidirezionali.
- Possibilità di montaggio di pompe multiple sia nelle serie in alluminio che con altre serie in ghisa prodotte da Ronzio Oleodinamica.
- Facilità di trasformazione: da pompa singola in pompa multipla e di cambio rotazione.

Main Features

- *Cast iron covers for high performances.*
- *High pressure option: up to 280 bar max. continuous pressure.*
- *Axial compensation achieved using pressure balanced bushing blocks.*
- *High volumetric efficiency: average 95-97%*
- *Wide range of capacities: 20-25-30-35-40-45-50-55-60-64-70-80-90 cm³/rev.*
- *Extruded aluminium body.*
- *Gear tooth profile accurately projected providing low noise operation.*
- *A wide variety of shafts, flanges and ports are available to meet specific application requirements.*
- *High-temperature seals available.*
- *Single rotational pumps and motors.*
- *Bi-rotational pumps and motors.*
- *Multiple pumps availability: tandem pumps are possible both in aluminium series and with other cast iron series produced by Ronzio Oleodinamica.*
- *Easy-to-make tandem pumps and easy change of rotation.*

CONDIZIONI PER L'UTILIZZO DELLE POMPE E MOTORI "Z3"

USE CONDITIONS FOR PUMPS AND MOTORS "Z3"

Nell'utilizzo della pompa evitare carichi radiali e assiali sull'albero.

Il giunto di trascinamento deve compensare eventuali errori di allineamento, deve essere di tipo elastico oppure di tipo Oldham.

Per un corretto funzionamento e una lunga durata della pompa, osservare i valori riportati nella tabella seguente.

Avoid radial and axial loads on the pump shaft during the use.

The pump must be in line with the P.T.O. To compensate misalignment errors, use flexible or "Oldham" coupling.

We recommend to read the specifications in this catalogue very carefully. This will help you in getting the best, in terms of working conditions and life, from Ronzio gear pumps.

CONDIZIONI DI UTILIZZO
USE CONDITIONS

Fluidi idraulici Hydraulic fluids	Oli idraulici a base minerale (DIN 51524). Per utilizzo di fluidi non infiammabili come acqua e glicole, emulsione di olio in acqua o esteri fosforici, contattare il nostro ufficio tecnico o commerciale. Mineral oil (DIN 51524). For use with fire resistant fluids like water glycol, water-oil emulsion and phosphate-esters, contact our technical or commercial office.			
Pressione in aspirazione Inlet pressure	0.7 - 3 bar (Assoluti / Absolute) 10 - 44 psi (Assoluti / Absolute)			
Velocità olio nella linea di aspirazione Oil speed on suction line	0.5 ÷ 1.5 m/s			
Velocità olio nella linea di mandata Oil speed on pressure line	6 ÷ 10 m/s			
Temperatura olio Oil temperature	-10°C ÷ 80°C			
Viscosità olio Oil viscosity	20 ÷ 120 mm ² /s (Cst)			
Massima viscosità olio all'avvio Max starting viscosity	700 mm ² /s (Cst)			
Filtraggio olio Oil filtration	Pressione (bar) Pressure (bar)	< 140	140 > 210	>210
	Classe di contaminazione NAS 1638 Contamination class NAS 1638	10	9	8
	Classe di contaminazione ISO 4406:1999 Contamination class ISO 4406:1999	21/19/16	20/18/15	19/17/14
	Rapporto β ₁₀ ≥ 75 - ISO16889 Ratio β ₁₀ ≥ 75 - ISO16889	//	10 μm	10 μm
	Rapporto β ₂₅ ≥ 200 - ISO16889 Ratio β ₂₅ ≥ 200 - ISO16889	25 μm	//	//

FORMULE PER DIMENSIONAMENTO
DETERMINATION OF NOMINAL SIZE

PER POMPE
FOR PUMP

$$Q = \frac{V * \eta_v * n}{1000}$$

$$M = \frac{p * V}{62.8 * \eta_m}$$

$$P = \frac{p * Q}{600 * \eta_t}$$

PER MOTORI
FOR MOTOR

$$Q = \frac{V * n}{1000 * \eta_v}$$

$$M = \frac{p * V * \eta_m}{62.8}$$

$$P = \frac{p * Q * \eta_t}{600}$$

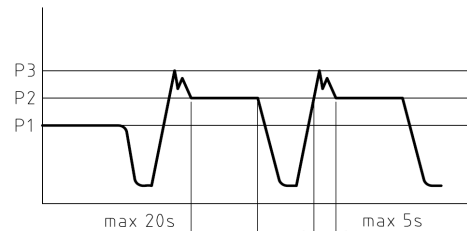

V [cm³]
Q [l/min]
p [bar]
M [Nm]
n [min⁻¹]
P [Kw]

η_v = EFF vol. ≥ 95
η_m = EFF mecc. ~ 0.85
η_t = η_v * η_m. ~ 0.8

CARATTERISTICHE PRINCIPALI

MAIN CHARACTERISTICS

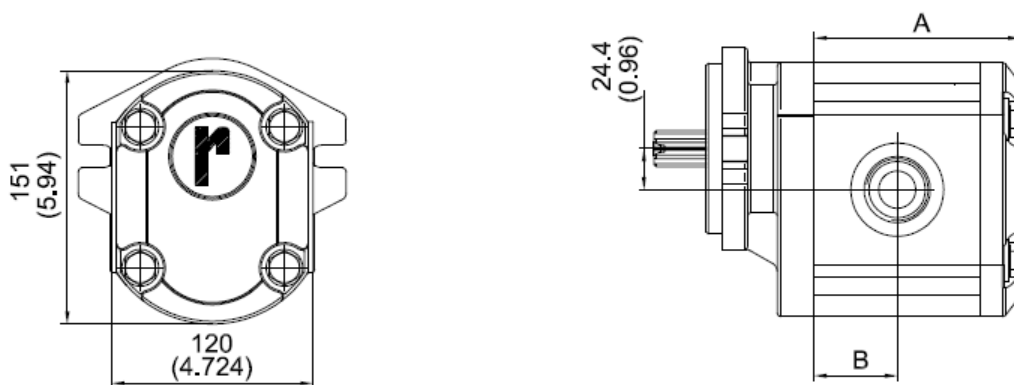

	20	25	30	35	40	45	50	55	60	64	70	80	90
CILINDRATA / CAPACITY cm ³ /giro at 1000 (giri/min)	19.9	24.9	29.9	34.3	40.5	45.2	49.9	54.5	60	63.9	70	78.7	89.6
PORTATA / DELIVERY L/min at 1500 (giri/min)	29.9	37.4	44.9	51.5	60.8	67.8	74.9	81.8	90	95.9	105	118	134.4
A (mm)	100.8	104	107.2	110	114	117	120	123	126.5	129	132.9	138.6	145.6
B (mm)	38.5	40	41.6	43	45	46.5	48	49.5	51	52.5	54.5	57.3	60.8

P1 Pressione max continua (bar) Max working pressure (bar)	280	280	280	280	250	250	230	230	200	200	170	170	160
P2 Pressione max di picco (bar) Max peak pressure (bar)	310	310	310	310	280	280	250	250	220	220	190	190	180
Velocità min per P1 (giri/min) Min speed for P1 pressure (Rpm)	450	450	350	350	350	350	350	350	350	350	350	350	350
Velocità max a vuoto (giri/min) Max speed without load (Rpm)	3000	3000	3000	3000	2700	2700	2200	2200	2000	2000	1800	1800	1800
Coppia resa (Nm) Output torque (Nm)	26.9	33.7	40.4	46.4	54.8	61.1	67.5	73.7	81.2	86.4	94.7	106.5	121.2
Massa (Kg) Weight (Kg)	10.6	10.8	11	11.2	11.4	11.5	11.7	11.9	12	12.2	12.4	12.7	13.1

VERIFICARE, ATTRAVERSO LE FORMULE SOTTO RIPORTATE, LA COMPATIBILITÀ TRA LE PRESTAZIONI DI PRESSIONE E PORTATA RICHIESTE, E LA CAPACITÀ DELL'ALBERO DI TRASCINAMENTO DI SOPPORTARE LA COPPIA RICHIESTA.

VERIFY THE COMPATIBILITY AMONG PERFORMANCE OF PRESSURE, FLOW REQUIRED AND TORQUE OF THE SHAFT THROUGH THE BELOW FORMULAS.

Per pompe o motori bidirezionali, diminuire la pressione del 15%.
With bidirectional pumps or motors, pressure is reduced by 15%.

COMPONENTI
PARTS

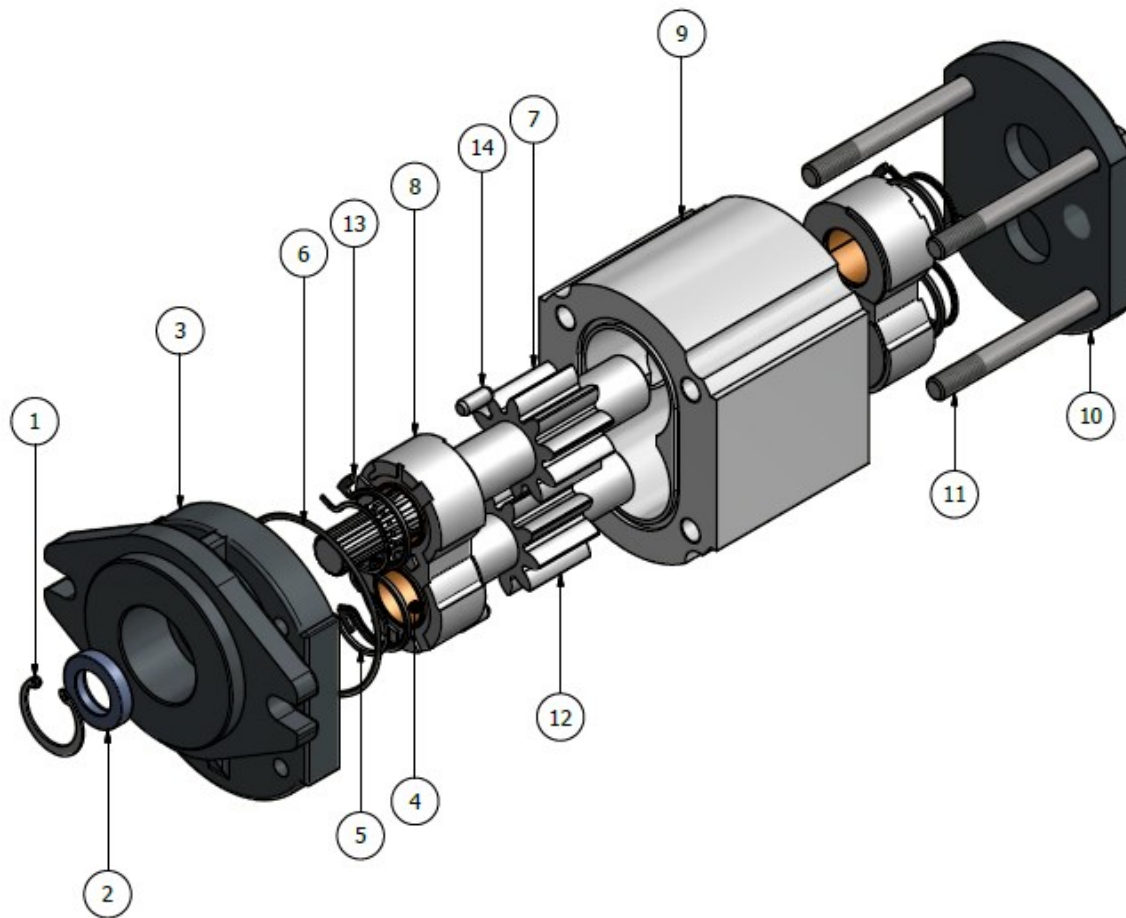

Rif.	Descrizione	Description	Qt.
1	Anello seeger	Snap ring	1
2	Anello di tenuta	Rotary shaft seal	1
3	Flangia	Front flange	1
4	Boccole	Bushings	4
5	Antiestrusore	BK seals	2
6	Guarnizione sotto-coperchio	Under cover seal	2
7	Ingranaggio conduttore	Drive gear	1
8	Rasamento	Bushing block	2
9	Corpo	Body	1
10	Coperchio posteriore	Rear cover	1
11	Vite	Bolt	4
12	Ingranaggio condotto	Idle gear	1
13	Guarnizione di compensazione	Compensation seal	2
14	Spine cilindriche	Pins	2

SENSO DI ROTAZIONE ROTATION

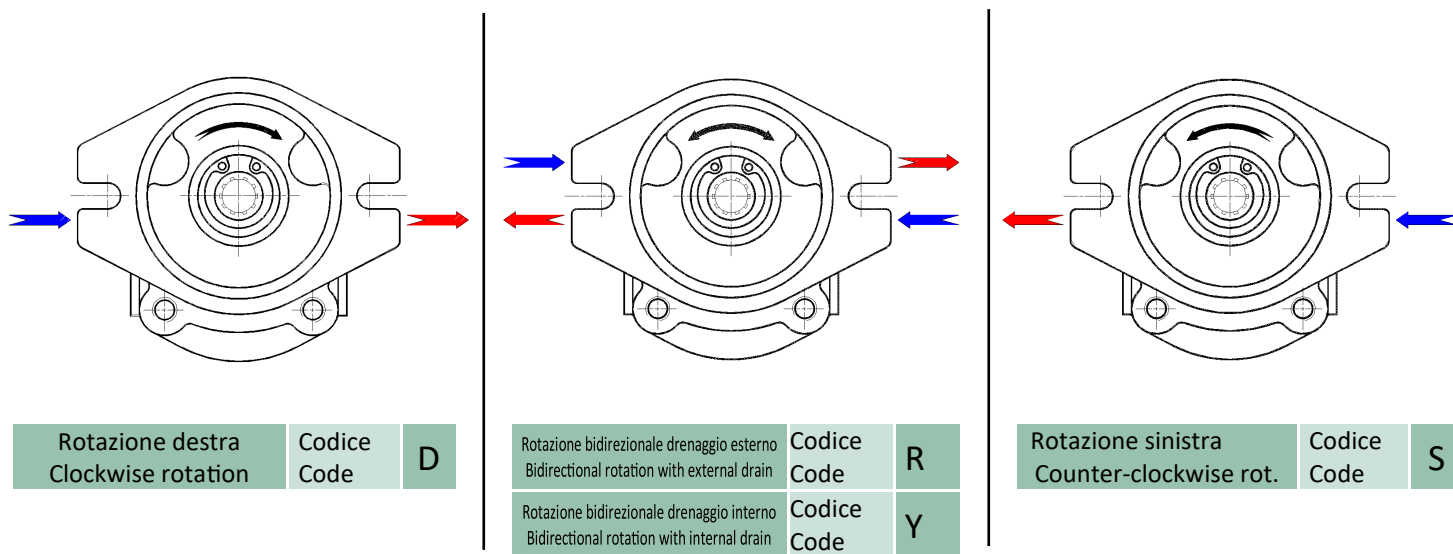

GUARNIZIONI PER ALBERI SHAFT SEAL

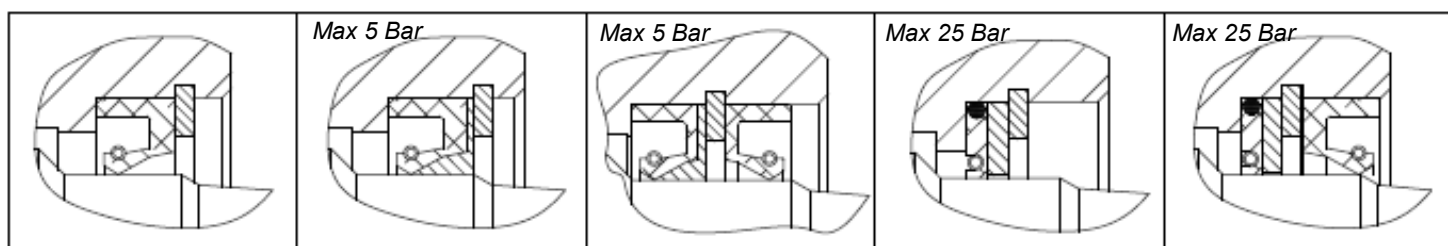

Codice Code	N	NBR	Codice Code	R	NBR	Codice Code	N2	NBR	Codice Code	B	//	Codice Code	BN	NBR
	V	FKM		RV	FKM		V2	FKM					BV	FKM
	H	HNBR		RH	HNBR									

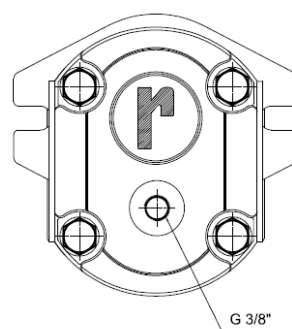
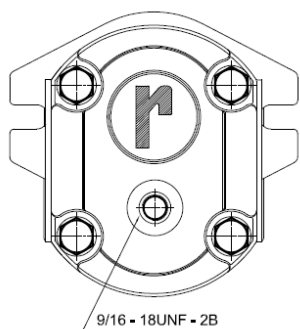

Drenaggio per pompe con flange
Drain for pumps with flanges

B2 - B3

Drenaggio per pompe con flange
Drain for pumps with flanges

A0 - C4 - D5

CAMBIO DEL SENSO DI ROTAZIONE DELLE POMPE Z3
CHANGING ROTATION OF THE PUMP Z3

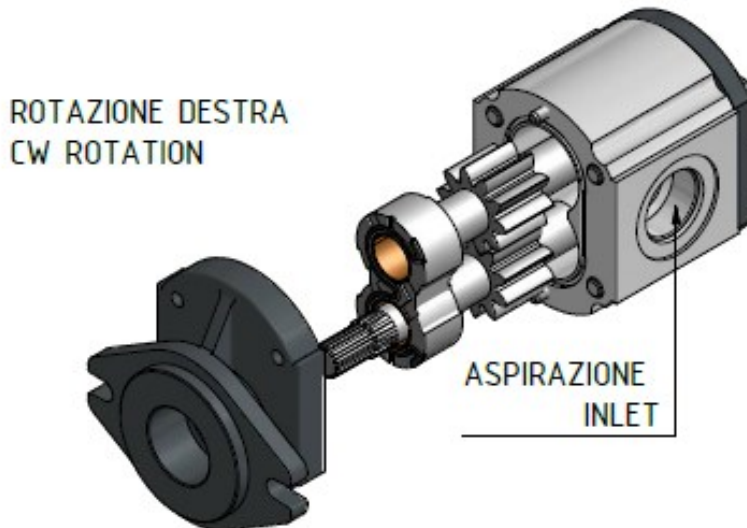
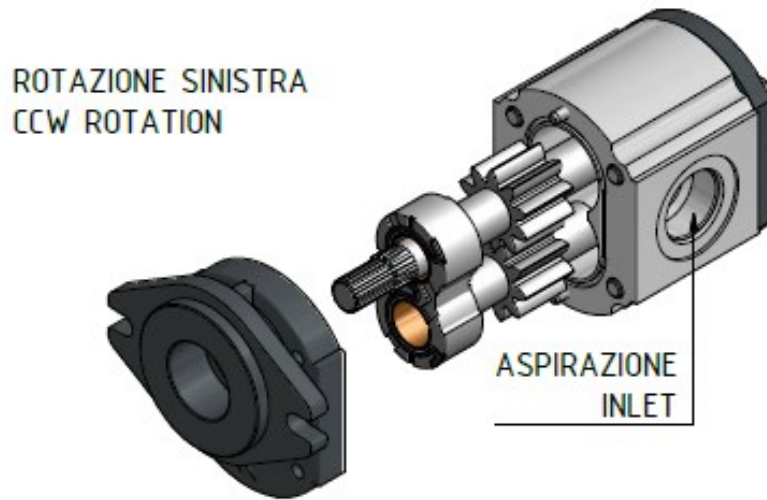

Il senso di rotazione è indicato con una freccia sul corpo della pompa.
An arrow on the housing of the pump indicates the rotation.

- Svitare le viti di fissaggio.
- Rimuovere la flangia tenendo premuto l'ingranaggio conduttore.
- Rimuovere contemporaneamente l'ingranaggio conduttore e il rasamento superiore mantenendo premuto l'ingranaggio condotto.
- Estrarre l'ingranaggio condotto tenendo fermo il rasamento inferiore, nel caso aiutarsi con una barretta NON metallica.
- Rimontare i due ingranaggi con posizioni invertite (vedi schema sopra).
- Rimontare il rasamento superiore facendo attenzione a NON invertirne la posizione.
- Rimontare la flangia utilizzando per le viti una coppia di serraggio di 120 Nm.

-
- *Unscrew the clamping bolts.*
 - *Remove the flange holding down the drive gear.*
 - *Remove the drive gear and the bushing block holding down the idle gear.*
 - *Remove the idle gear keeping down the rear bushing block with a no-metallic bar.*
 - *Reverse the position of the two gears (see picture above).*
 - *Replace the bushing block without rotating or changing position.*
 - *Reverse the flange and retighten the bolts to a torque rating between 88 ft/lbs.*

FLANGE
FLANGES

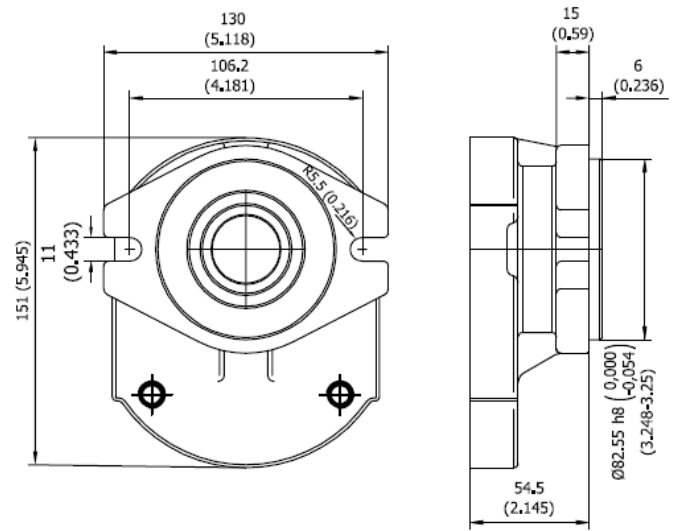
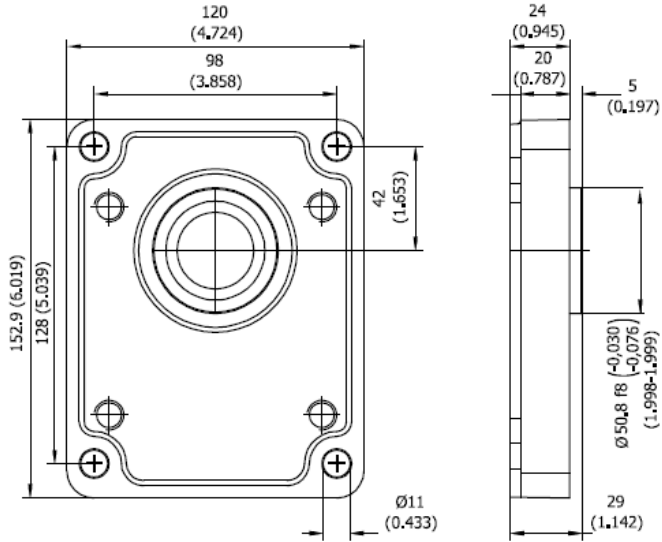

CODICE
CODE

A 0

NOTA: Materiale Ghisa
NOTE: Material Cast iron

CODICE
CODE

B 2

NOTA: Materiale Ghisa
NOTE: Material Cast iron

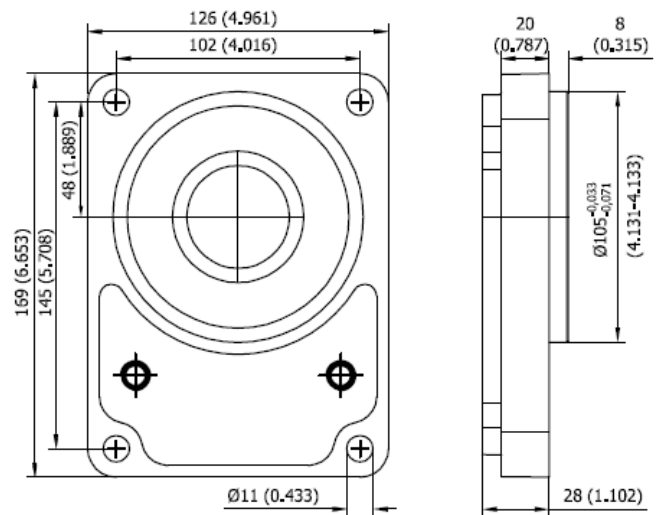
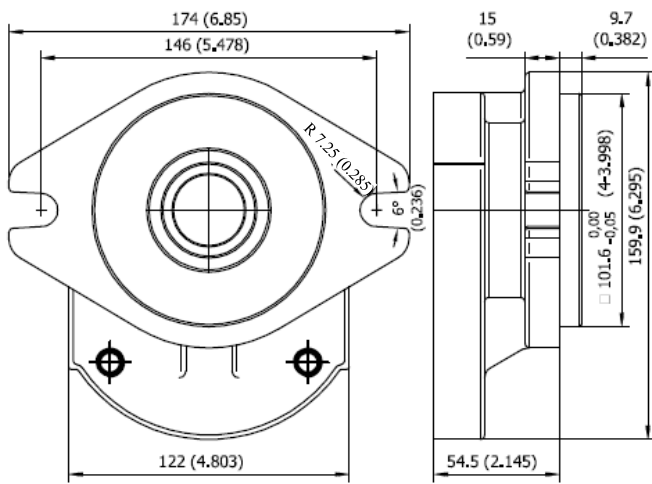

CODICE
CODE

B 3

NOTA: Materiale Ghisa
NOTE: Material Cast iron

CODICE
CODE

C 4

NOTA: Materiale Ghisa
NOTE: Material Cast iron

FLANGE
FLANGES

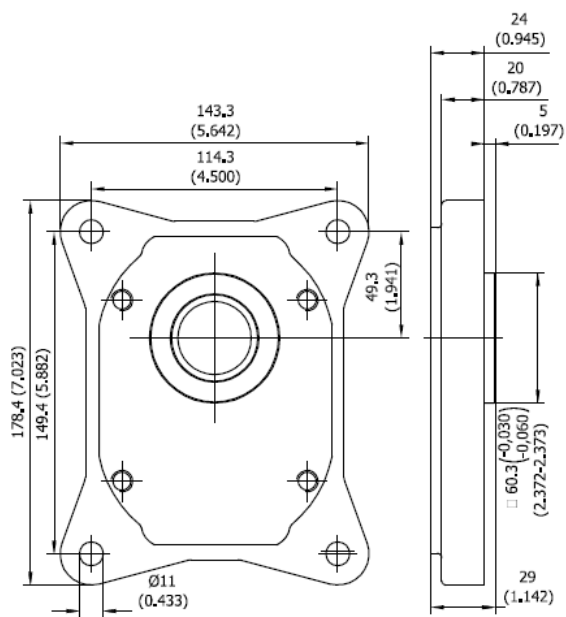

CODICE
CODE

D 5

NOTA: Materiale Ghisa
NOTE: Material Cast iron

CONICO 1:8

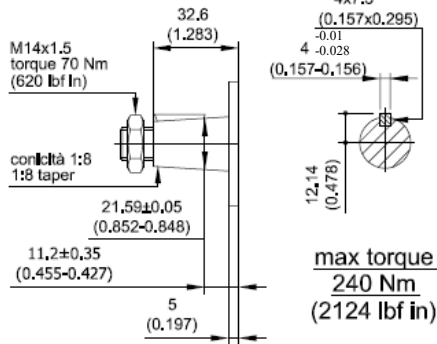

CODICE / CODE	C
PER FLANGIA / FOR FLANGE	A 0

CONICO 1:5

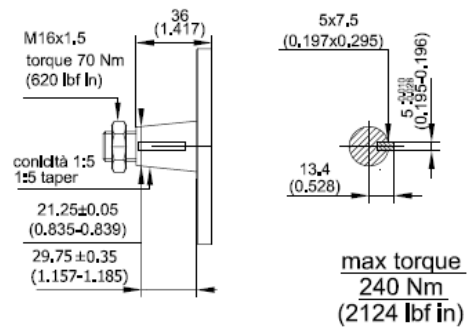

CODICE / CODE	A
PER FLANGIA / FOR FLANGE	C 4

SAE "B" SCANALATO

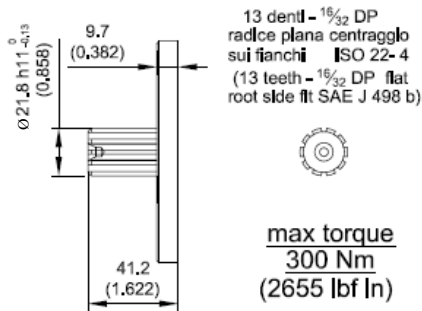

CODICE / CODE	B
PER FLANGIA / FOR FLANGE	B 2
	B 3

SAE "B" CILINDRICO 7/8"

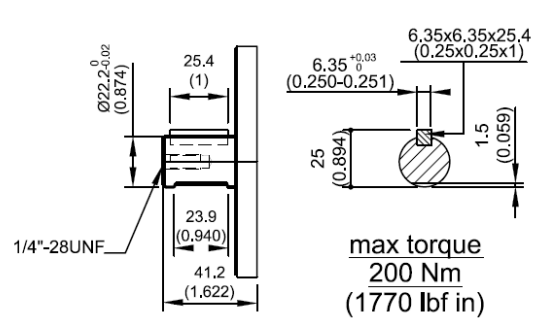

CODICE / CODE	L
PER FLANGIA / FOR FLANGE	B 2
	B 3

CILINDRICO

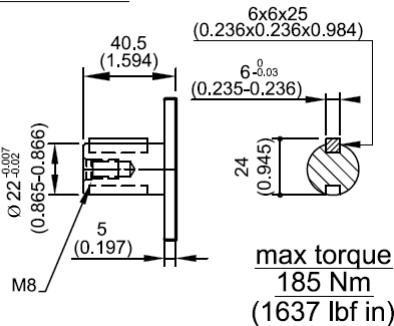

CODICE / CODE	Q
PER FLANGIA / FOR FLANGE	A 0
	D 5

SAE "B" CILINDRICO 1"

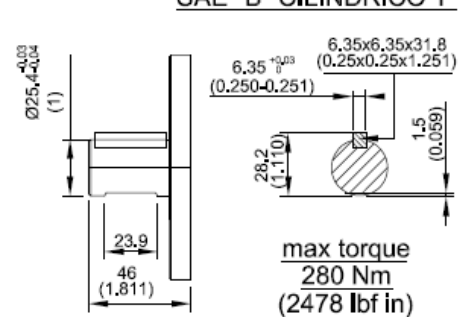

CODICE / CODE	M
PER FLANGIA / FOR FLANGE	B 2
	B 3

ALBERI
SHAFTS

CONICO 3,5

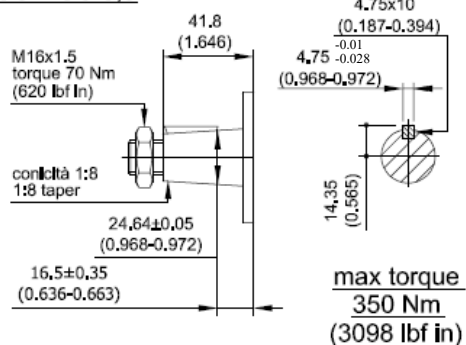

CODICE / CODE	R
PER FLANGIA / FOR FLANGE	D 5

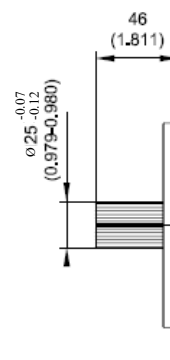

SAE 15 DENTI

15 denti - 1/32 DP
radice plana centraggio
sul fianco
(15 teeth - 1/32 DP flat
root side fit)

max torque
450 Nm
(3983 lbf in)

CODICE / CODE	SS
PER FLANGIA / FOR FLANGE	B 3

BOCCHIE DI ASPIRAZIONE E MANDATA INLET AND OUTLET PORTS

XX STANDARD

XX SU ORDINAZIONE / ON DEMAND

NON DISPONIBILI / NOT AVAILABLE

	X	Y	Z
A	19	40	M8 18
B	27	51	M10 18
C	33	62	M12 18

		OUT		
		A	B	C
IN	A	49		
	B	48	46	
	C		47	45

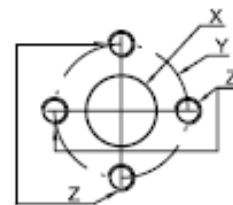

	X	Y	Z
A	19	55	M8 18
B	27	55	M8 18

		OUT	
		A	B
IN	A	50	
	B	51	52



	X	Y	Z	J
A	12.5	38.1	17.5	5/16-18UNC-2B
B	19	47.6	22.2	3/8-16UNC-2B
C	25.4	52.4	26.2	
D	30.5	58.7	30.2	7/16-14UNC-2B
E	39.3	69.8	35.7	1/2-13UNC-2B
F	51	77.8	42.9	

		OUT					
		A	B	C	D	E	F
IN	A	53					
	B	54	55				
	C		56	57			
	D			58	59		
	E				60	61	
	F					62	63

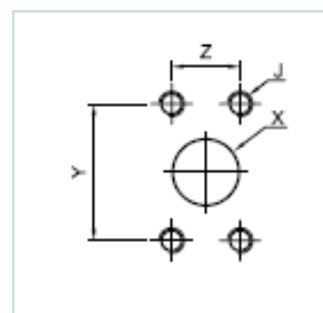

	X	Y	Z	DIMENSIONE NOMINALE
A	1" G	22	27	1
B	1" 1/4 G	22	33	1-1/4
C	1" 1/2 G	24	38	1-1/2

		OUT		
		A	B	C
IN	A	64		
	B	65	66	
	C		67	68

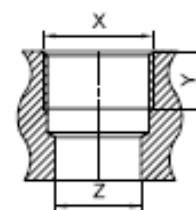

	DIMENSIONE NOMINALE	X	Y	Z	J
A	3/4"	1-1/16-12UN-2B	42	0.5	24.5
B	1"	1-5/16-12UN-2B	49	0.5	30.5
C	1"-1/4	1-5/8-12UN-2B	58	0.5	39
D	1"-1/2	1-7/8-12UN-2B	65	0.5	45

		OUT			
		A	B	C	D
IN	A	69			
	B	70	71		
	C		72	73	
	D			74	75

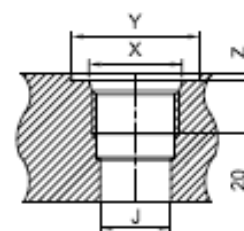

BOCCHIE DI ASPIRAZIONE E MANDATA
INLET AND OUTLET PORTS

CODICE BOCCHIE STANDARD DISPONIBILI IN RELAZIONE ALLE CILINDRATE
 STANDARD PORT CODES AVAILABLE IN RELATION TO CAPACITY

74													
73													
72													
71													
70													
69													
68													
67													
66													
65													
64													
63													
62													
61													
60													
59													
58													
57													
56													
55													
54													
53													
52													
51													
50													
49													
48													
47													
46													
45													
	20	25	30	35	40	45	50	55	60	64	70	80	90



BOCCHIE STANDARD / STANDARD PORTS

SUPPORTI INTEGRATI
INBOARD BEARINGS

TIPO 2 - TYPE 2

Supporto integrato con doppio cuscinetto a rulli conici

Integrated bearing support with double taper roller bearings

DISPONIBILE PER FLANGE
AVAILABLE FOR FLANGE

B2 - B3

DISPONIBILE PER ALBERI
AVAILABLE FOR SHAFT

A - S - M - L - B



DIAGRAMMA CARICHI RADIALI AMMISSIBILI
GRAPHIC OF RADIAL LOAD



Coppia massima di trascinamento 300 Nm
Max torque 300 Nm

DATI DI BASE PER STESURA GRAFICO

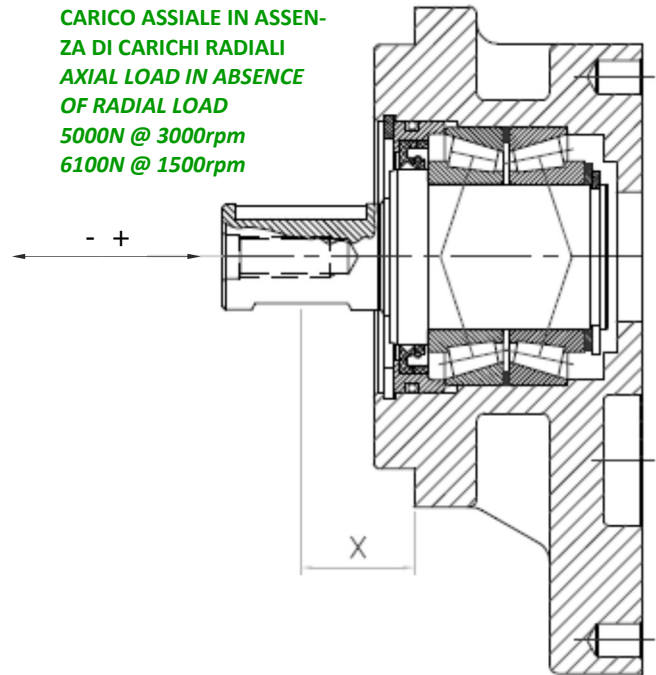
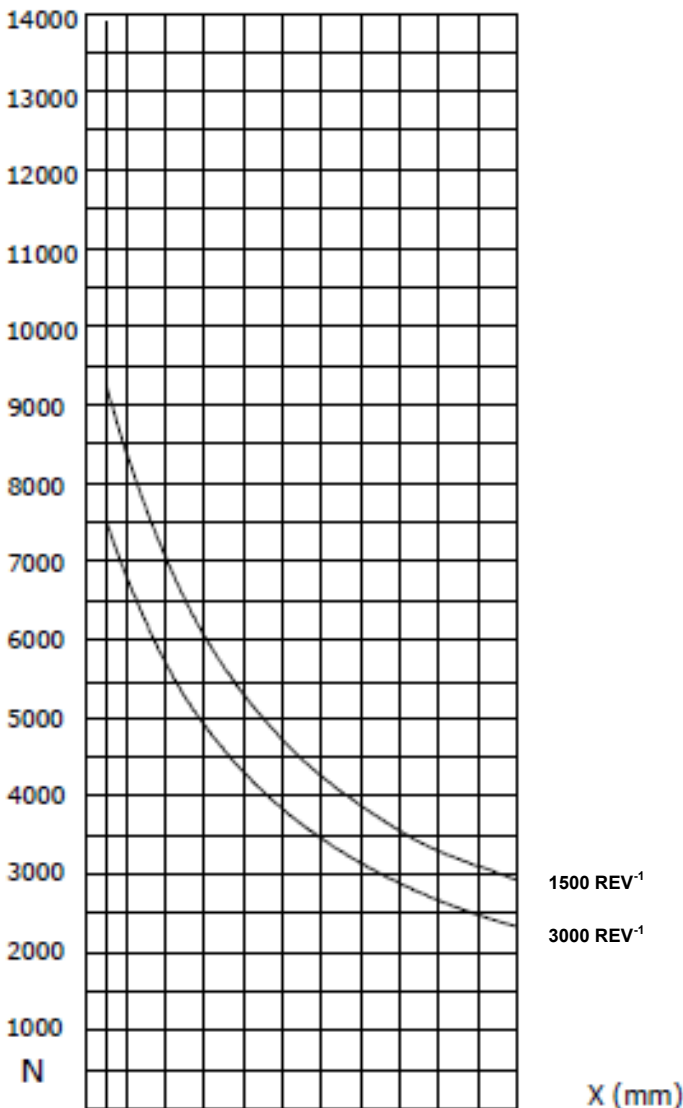
- Durata a fatica corretta 1000 h
- Olio VG-46
- Temperatura 60°C
- Affidabilità 90%
- Grado di contaminazione medio 30μ

IL VALORE DEI CARICHI É INFLUENZATO DALLE CONDIZIONI DI FUNZIONAMENTO

LOAD GRAPH

- Rating fatigue life 1000 h
- Oil type VG-46
- Temperature 60°C
- Trust 90%
- Contamination 30 μ

LOAD VALUE IS AFFECTED BY WORKING CONDITIONS

ISTRUZIONI PER ORDINARE UNITÁ SINGOLE Z3
HOW TO ORDER Z3 SINGLE UNITS

	1	2	3	4	5	6	7	8	9	10		
0	3	Z	A	G	35	C	0	48	S	-	1	B

1	TIPO UNITÁ / UNIT TYPE	CODICE / CODE
	POMPA / PUMP	Z
	MOTORE / MOTOR	ZM

2-5	FLANGIA / FLANGE (PAG. 9-10)	CODICE / CODE
	EUROPA / EUROPEAN	A - 0
	SAE "A" / SAE "A"	B - 2
	SAE "B" / SAE "B"	B - 3
	TEDESCA / GERMAN	C - 4
	EUROPEA GR. 3,5 / EUROPEA GR. 3,5	D - 5

3	CILINDRATA / CAPACITY cm ³	CODICE / CODE
	19.9	20
	24.9	25
	29.9	30
	34.5	35
	40.5	40
	45.2	45
	49.9	50
	54.5	55
	60	60
	63.9	64
	70	70
	78.7	80
	89.6	90

4	ALBERO / SHAFT (PAG. 11-12)	CODICE / CODE
	CONICO 1:8 / TAPERED 1:8	C
	CONICO 1:5 / TAPERED 1:5	A
	SAE "B" SCANALATO / SAE "B" SPLINED	B
	SAE "B" CIL. 7/8" / SAE "B" STRAIGHT 7/8"	L
	CILINDRICO Ø 22 / STRAIGHT Ø 22	Q
	SAE "B" CIL. 1" / SAE "B" STRAIGHT 1"	M
	CONICO GR. 3,5 / TAPERED GR. 3,5	R
	SAE 15 TH / SAE 15 TH	S

6	BOCCHIE / PORTS (PAG.13)	CODICE / CODE
	EUROPEE / EUROPEAN	49 - 48 - 46 - 47 - 45
	TEDESCHE / GERMAN	50 - 51 - 52
	BSPP	64 - 65 - 66 - 67 - 68
	O-RING BOSS	69 - 70 - 71 - 72 - 73 - 74 - 75
	SAE 3000 PSI	53 - 54 - 55 - 56 - 57 - 58 - 59 - 60 - 61 - 62 - 63

7	ROTAZIONE / ROTATION	CODICE / CODE
	DESTRO / RIGHT	D
	SINISTRO / LEFT	S
	BIDIREZIONALE DRENAGGIO INTERNO BIDIRECTIONAL WITH INTERNAL DRAIN	Y
	BIDIREZIONALE DRENAGGIO ESTERNO BIDIRECTIONAL WITH EXTERNAL DRAIN	R

8	TIPO UNITÁ / UNIT TYPE	CODICE / CODE
	PREDISPOSTA TANDEM / FOR TANDEM	T
	NORMALE / NORMAL	-

9	SUPPORTO INTEGRATO / INBOARD BEARINGS	CODICE / CODE
	TIPO 1 / TYPE 1	1
	NESSUNO / NORMAL	-

10	PARAOILIO / SHAFT SEAL (PAG.7)	CODICE / CODE
	STANDARD / STANDARD	N
	STANDARD FKM / STANDARD FKM	V
	STANDARD HNBR / STANDARD HNBR	H
	5 BAR NBR / 5 BAR NBR	R
	5 BAR FKM / 5 BAR FKM	RV
	5 BAR NBR / 5 BAR NBR	RH
	DOPPIO MIM NBR / DOUBLE SEAL NBR	N2
	DOPPIO MIM FKM / DOUBLE SEAL FKM	V2
	25 BAR PTFE NBR / 25 BAR PTFE NBR	B
	25 BAR NBR / 25 BAR NBR	BN
	25 BAR FKM / 25 BAR FKM	BV

KIT DI MONTAGGIO POMPE MULTIPLE Z3 CON STADI A FLUSSI SEPARATI
ASSEMBLING KIT FOR MULTIPLE PUMPS Z3 WITH SEPARATED FLOW

Z3/Z3/Z3

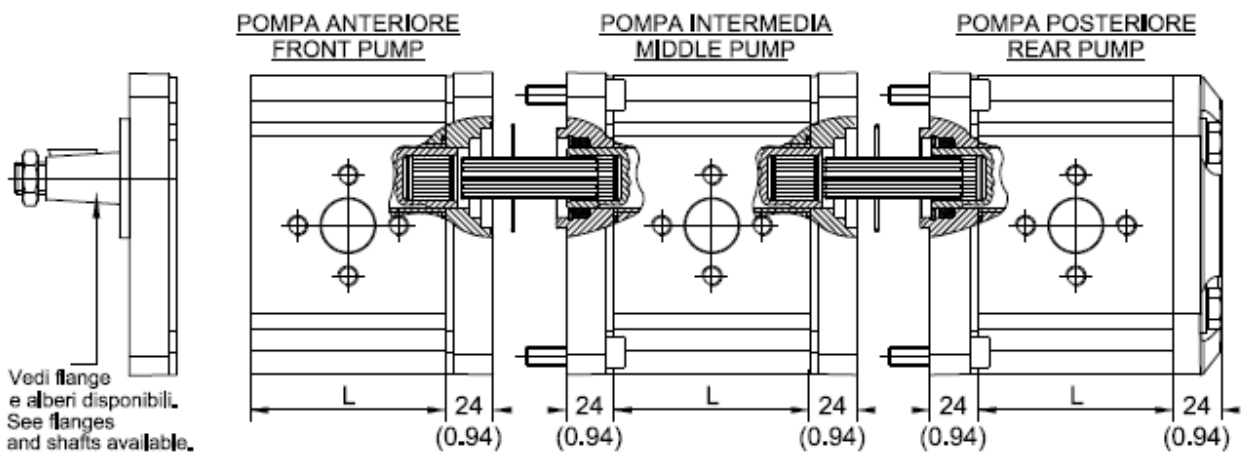
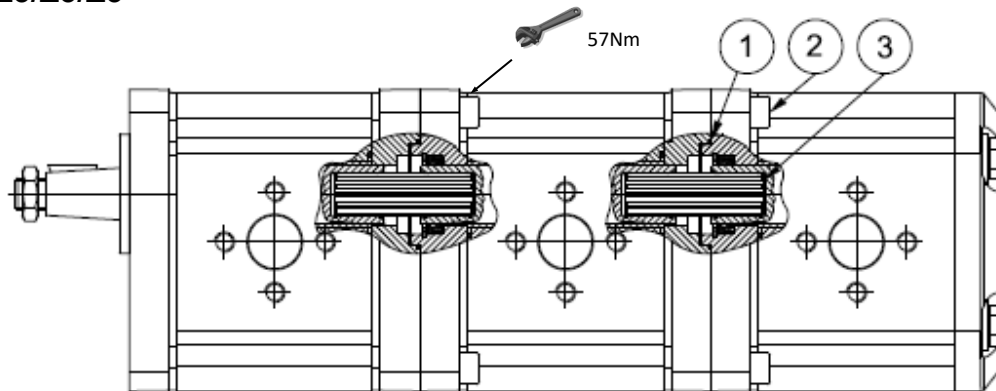
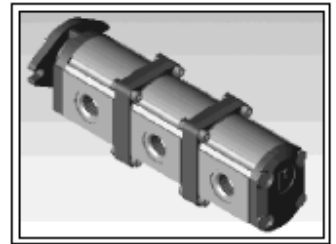

KIT INTERMEDIO Z3-Z3
MIDDLE KIT Z3-Z3

C.C.	L
20	77
25	80
30	83.2
35	86
40	90
45	93
50	96
55	99
60	102
64	105
70	109
80	114.6
90	121.6

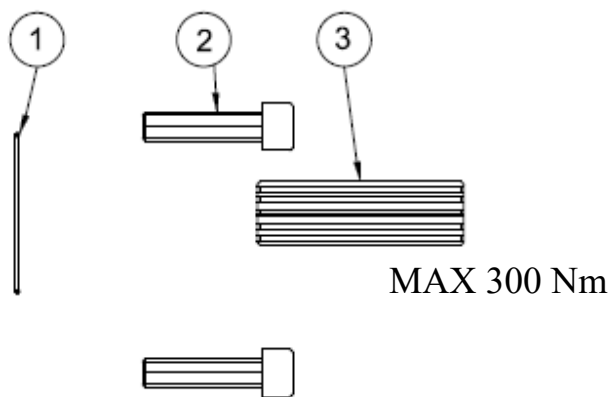

Codice Kit: Code Kit.: K 300034	
Ref.	PARTI / PARTS
1	OR178/5052
2	VITI M10x40
3	Albero scanalato 22x19 Splined shaft 22x19

Disponibile anche nella versione compatta con aspirazione comune.
 Available in compact version with common inlet.

ISTRUZIONI PER ORDINARE UNITÁ MULTIPLE Z3
HOW TO ORDER Z3 MULTIPLE UNITS

			1		2		3		4		5		6		7
0	3	Z	A	G	80	E	0	48	A	S	B				

POMPA ANTERIORE
FRONT PUMP

					2				5		6		7
0	3	Z	A	G	45	0	0	48	I	S	B		

POMPA INTERMEDIA
MIDDLE PUMP

					2				5		6		7
0	3	Z	A	G	45	0	0	48	P	S	B		

POMPA POSTERIORE
REAR PUMP

1-4	FLANGIA / FLANGE (PAG. 9-10)	CODICE / CODE
	EUROPA / EUROPEAN	A - 0
	SAE "A" / SAE "A"	B - 2
	SAE "B" / SAE "B"	B - 3
	TEDESCA / GERMAN	C - 4
	EUROPEA GR. 3,5 / EUROPEA GR. 3,5	D - 5

5	BOCCHIE / PORTS (PAG. 13)	CODICE / CODE
	EUROPEE / EUROPEAN	49 - 48 - 46 - 47 - 45
	TEDESCHE / GERMAN	50 - 51 - 52
	BSPP	64 - 65 - 66 - 67 - 68
	O-RING BOSS	69 - 70 - 71 - 72 - 73 - 74 - 75
	SAE 3000 PSI	53 - 54 - 55 - 56 - 57 - 58 - 59 - 60 - 61 - 62 - 63

2	CILINDRATA / CAPACITY cm ³	CODICE / CODE
	19.9	20
	24.9	25
	29.9	30
	34.3	35
	40.5	40
	45.2	45
	49.9	50
	54.5	55
	60	60
	63.9	64
	70	70
	78.7	80
	89.6	90

6	ROTAZIONE / ROTATION	CODICE / CODE
	DESTRO / RIGHT	D
	SINISTRO / LEFT	S

3	ALBERO / SHAFT (PAG. 11-12)	CODICE / CODE
	CONICO 1:8 / TAPERED 1:8	C
	CONICO 1:5 / TAPERED 1:5	A
	SAE "B" SCANALATO / SAE "B" SPLINED	B
	SAE "B" CIL. 7/8" / SAE "B" STRAIGHT 7/8"	L
	CILINDRICO Ø 22 / STRAIGHT Ø 22	Q
	SAE "B" CIL. 1" / SAE "B" STRAIGHT 1"	M
	CONICO GR. 3,5 / TAPERED GR. 3,5	R
	SAE 15 TH / SAE 15 TH	S

7	PARAOILIO / SHAFT SEAL (PAG.7)	CODICE / CODE
	STANDARD / STANDARD	N
	STANDARD FKM / STANDARD FKM	V
	STANDARD HNBR / STANDARD HNBR	H
	5 BAR NBR / 5 BAR NBR	R
	5 BAR FKM / 5 BAR FKM	RV
	5 BAR NBR / 5 BAR NBR	RH
	DOPPIO MIM NBR / DOUBLE SEAL NBR	N2
	DOPPIO MIM FKM / DOUBLE SEAL FKM	V2
	25 BAR PTFE NBR / 25 BAR PTFE NBR	B
	25 BAR NBR / 25 BAR NBR	BN
	25 BAR FKM / 25 BAR FKM	BV

KIT DI MONTAGGIO POMPE MULTIPLE Z3/Z1 - Z3/Z2 CON STADI A FLUSSI SEPARATI
ASSEMBLING KIT FOR MULTIPLE PUMPS Z3/Z1 - Z3/Z2 WITH SEPARATED FLOW

Z3/Z1

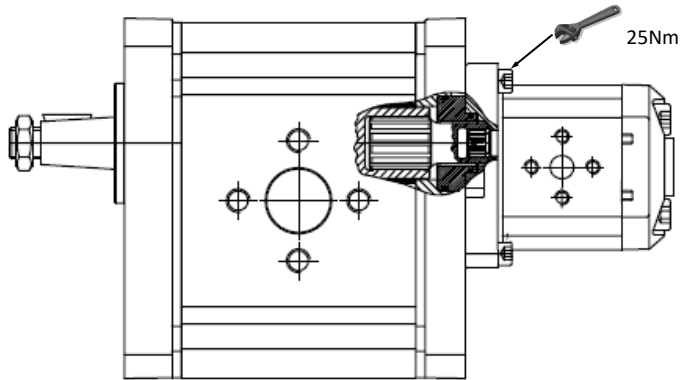
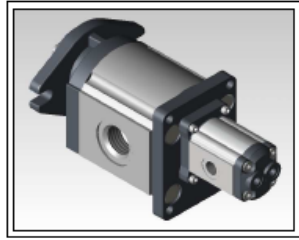

Z3/Z2

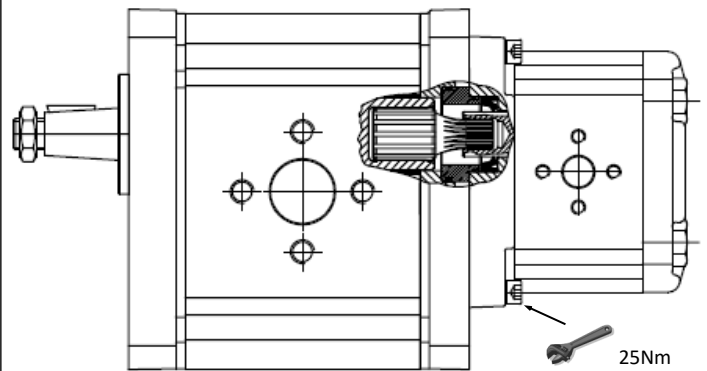
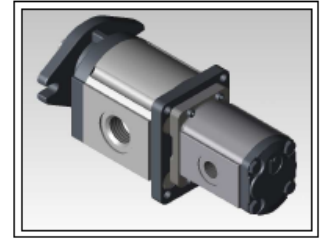

KIT INTERMEDIO Z3-Z1
MIDDLE KIT Z3-Z1

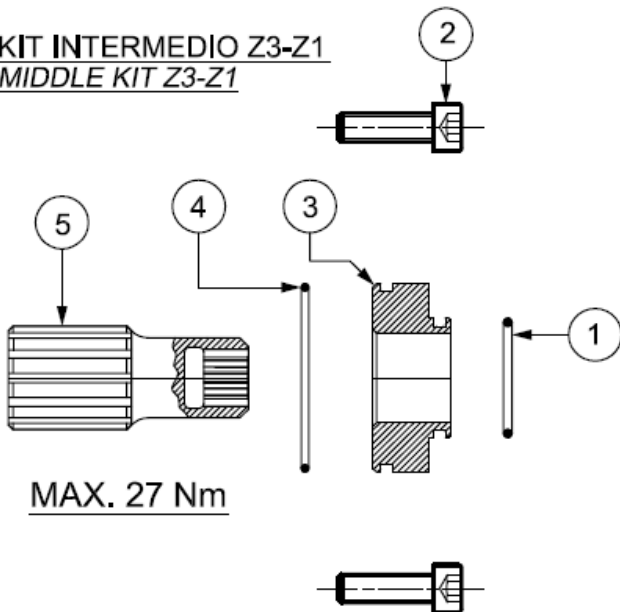

Codice Kit: Code Kit.: K3000029	
Ref.	PARTI / PARTS
1	ORM0210-20
2	VITI M6x25
3	Bussola di centraggio / Pilot ring
4	ORM0360
5	Albero scanalato / Splined shaft

KIT INTERMEDIO Z3-Z2
MIDDLE KIT Z3-Z2

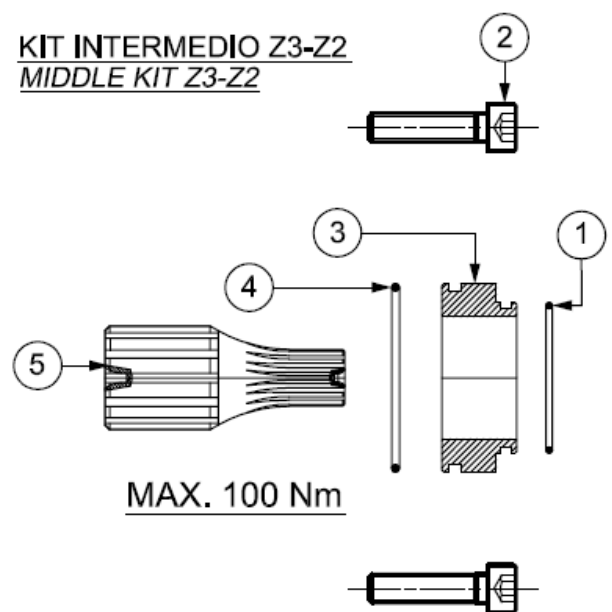

Codice Kit: Code Kit.: K3000030	
Ref.	PARTI / PARTS
1	OR2112
2	VITI M6x25
3	Bussola di centraggio / Pilot ring
4	ORM0360
5	Albero scanalato / Splined shaft

Disponibile anche nella versione compatta con aspirazione comune e con altre pompe Z2 - Z1.
 Available in compact version with common inlet and possibility of tandem pump with our Z2 - Z1.

ISTRUZIONI PER ORDINARE UNITÁ MULTIPLE Z3 HOW TO ORDER Z3 MULTIPLE UNITS

	1		2		3		4		5		6		7
0	3	Z	A	G	80	E	0	48	A	S	B		

POMPA ANTERIORE Z3
FRONT PUMP Z3

K3000029

KIT TANDEM Z3/Z1
TANDEM KIT Z3/Z1

					8*				9*		6		7
0	1	Z	A	G	21	0	0	48	I	S	B		

POMPA INTERMEDIA Z1
MIDDLE PUMP Z1

					8*				9*		6		7
0	1	Z	A	G	21	0	0	48	P	S	B		

POMPA POSTERIORE Z1
REAR PUMP Z1

1 - 4	FLANGIA / FLANGE (PAG. 9-10)	CODICE / CODE
	EUROPA / EUROPEAN	A - 0
	SAE "A" / SAE "A"	B - 2
	SAE "B" / SAE "B"	B - 3
	TEDESCA / GERMAN	C - 4
	EUROPEA GR. 3,5 / EUROPEA GR. 3,5	D - 5

5	BOCCHIE / PORTS (PAG.13)	CODICE / CODE
	EUROPEE / EUROPEAN	SEE PAGE 13-14
	TEDESCHE / GERMAN	SEE PAGE 13-14
	BSPP	SEE PAGE 13-14
	O-RING BOSS	SEE PAGE 13-14
	SAE 3000 PSI	SEE PAGE 13-14

2	CILINDRATA / CAPACITY cm ³	CODICE / CODE
	19.9	20
	24.9	25
	29.9	30
	34.3	35
	40.5	40
	45.2	45
	49.9	50
	54.5	55
	60	60
	63.9	64
	70	70
	78.7	80
	89.6	90

6	ROTAZIONE / ROTATION	CODICE / CODE
	DESTRO / RIGHT	D
	SINISTRO / LEFT	S

7	PARAOILIO / SHAFT SEAL (PAG.7)	CODICE / CODE
	STANDARD / STANDARD	N
	STANDARD FKM / STANDARD FKM	V
	STANDARD HNBR / STANDARD HNBR	H
	5 BAR NBR / 5 BAR NBR	R
	5 BAR FKM / 5 BAR FKM	RV
	5 BAR NBR / 5 BAR NBR	RH
	DOPPIO MIM NBR / DOUBLE SEAL NBR	N2
	DOPPIO MIM FKM / DOUBLE SEAL FKM	V2

3	ALBERO / SHAFT (PAG. 11-12)	CODICE / CODE
	CONICO 1:8 / TAPERED 1:8	C
	CONICO 1:5 / TAPERED 1:5	A
	SAE "B" SCANALATO / SAE "B" SPLINED	B
	SAE "B" CIL. 7/8" / SAE "B" STRAIGHT 7/8"	L
	CILINDRICO Ø 22 / STRAIGHT Ø 22	Q
	SAE "B" CIL. 1" / SAE "B" STRAIGHT 1"	M
	CONICO GR. 3,5 / TAPERED GR. 3,5	R
	SAE 15 TH / SAE 15 TH	S

8	CILINDRATA / CAPACITY cm ³	CODICE / CODE
	0.80	08
	1.08	11
	1.59	16
	2.09	21
	2.59	26
	3.15	32
	3.68	37
	4.19	42
	4.79	48
	5.49	55
	6.2	62
	7.81	78
	8.82	88
	10.5	105

*** VEDI ANCHE CATALOGO Z1 / SEE ALSO Z1 CATALOGUE**

ISTRUZIONI PER ORDINARE UNITÁ MULTIPLE Z3 HOW TO ORDER Z3 MULTIPLE UNITS

			1		2		3		4		5		6		7
0	3	Z	A	G	80	E	0	48	A	S	B				

POMPA ANTERIORE Z3
FRONT PUMP Z3

K3000030

KIT TANDEM Z3/Z2
TANDEM KIT Z3/Z2

					8*			9*		6	7
0	2	Z	A	G	14	0	0	48	I	S	B

POMPA INTERMEDIA Z2
MIDDLE PUMP Z2

					8*			9*		6	7
0	2	Z	A	G	14	0	0	48	P	S	B

POMPA POSTERIORE Z2
REAR PUMP Z2

1 - 4	FLANGIA / FLANGE (PAG. 9-10)	CODICE / CODE
	EUROPA / EUROPEAN	A - 0
	SAE "A" / SAE "A"	B - 2
	SAE "B" / SAE "B"	B - 3
	TEDESCA / GERMAN	C - 4
	EUROPEA GR. 3,5 / EUROPEA GR. 3,5	D - 5

5	BOCCHIE / PORTS (PAG. 13)	CODICE / CODE
	EUROPEE / EUROPEAN	SEE PAGE 13-14
	TEDESCHE / GERMAN	SEE PAGE 13-14
	BSPP	SEE PAGE 13-14
	O-RING BOSS	SEE PAGE 13-14
	SAE 3000 PSI	SEE PAGE 13-14

2	CILINDRATA / CAPACITY cm ³	CODICE / CODE
	19.9	20
	24.9	25
	29.9	30
	34.3	35
	40.5	40
	45.2	45
	49.9	50
	54.5	55
	60	60
	63.9	64
	70	70
	78.7	80
	89.6	90

6	ROTAZIONE / ROTATION	CODICE / CODE
	DESTRO / RIGHT	D
	SINISTRO / LEFT	S

7	PARAOILIO / SHAFT SEAL (PAG. 7)	CODICE / CODE
	STANDARD / STANDARD	N
	STANDARD FKM / STANDARD FKM	V
	STANDARD HNBR / STANDARD HNBR	H
	5 BAR NBR / 5 BAR NBR	R
	5 BAR FKM / 5 BAR FKM	RV
	5 BAR NBR / 5 BAR NBR	RH
	DOPPIO MIM NBR / DOUBLE SEAL NBR	N2
	DOPPIO MIM FKM / DOUBLE SEAL FKM	V2

3	ALBERO / SHAFT (PAG. 11-12)	CODICE / CODE
	CONICO 1:8 / TAPERED 1:8	C
	CONICO 1:5 / TAPERED 1:5	A
	SAE "B" SCANALATO / SAE "B" SPLINED	B
	SAE "B" CIL. 7/8" / SAE "B" STRAIGHT 7/8"	L
	CILINDRICO Ø 22 / STRAIGHT Ø 22	Q
	SAE "B" CIL. 1" / SAE "B" STRAIGHT 1"	M
	CONICO GR. 3,5 / TAPERED GR. 3,5	R
	SAE 15 TH / SAE 15 TH	S

8	CILINDRATA / CAPACITY cm ³	CODICE / CODE
	4.4	04
	6.3	06
	8.15	08
	11.3	11
	14.5	14
	16.9	17
	20.1	20
	25.7	25
	31.4	31

* VEDI ANCHE CATALOGO Z2/SEE ALSO Z2 CATALOGUE

Ronzio Oleodinamica si riserva di apportare in qualunque momento modifiche ai modelli descritti sia per ragioni di natura tecnica che commerciale.
Riproduzione vietata.

Ronzio Oleodinamica reserves the right to make change to the product described here in any time it deems fit in relation to technical or commercial requirements.



VIALE INDUSTRIA 37/39, 20010 BOFFALORA TICINO -MI- ITALY
TEL.+39 02 9754057 FAX+39 02 97255070
E-mail sales@ronzio.com - www.ronzio.com