



HCM4100S1

Technical Data Sheet



HCM4100S1 Hybrid Sensor with Gyro



- 2 Axis inclinometer
- Gyroscope
- 20 configurable I/O's
- 1 CANbus
- 1 RS232
- Intelligent CANopen profile
- Designed for operation at both 12V and 24V

HCM4100S1 Hybrid Sensor features combined high performance angular rate sensor (gyroscope), dual accelerometer and programmable controller with 20 configurable I/O lines. Sensor is targeted for tough environmental conditions for applications where high stability is demanded.

Advanced sensor design minimises disturbances from mechanical shocks and vibration.

Technical Information

- 9-32V operating voltage range
(Protected against reverse polarity)
- Less than 100mA current consumption at no load
- $\pm 90^\circ$ inclinometer measuring range (X & Y)
0.1° accuracy ($\pm 45^\circ$)
0.5° accuracy ($-85^\circ \dots -45^\circ$ and $45^\circ \dots 85^\circ$)
- Gyro for Z axis
 $\pm 300^\circ/\text{sec}$ angular rate sensing
- $-40 \dots +85^\circ\text{C}$ operating temperature range
- 32-bit microprocessor
- IP67 aluminium housing
- Weight 0.6kg
- Main dimensions 112mm x 102mm x 34mm
- One 26 pin AMP Super Seal connector
- CAN interface 2.0B, ISO 11898
- RS232 interface

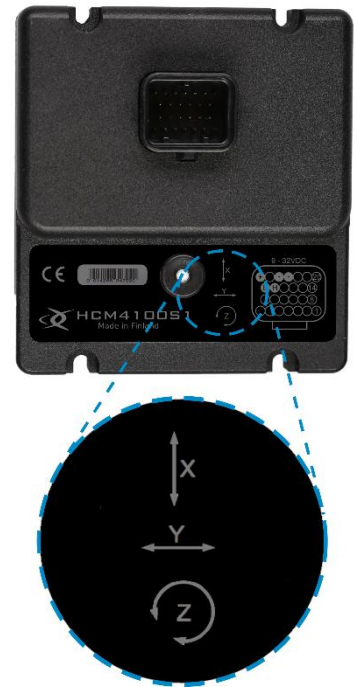

I/O Interface

- Total of 20 configurable I/O-lines
- The I/O interface is protected against short to GND and to supply voltage
- Configurable reference voltage: 5V / 10V, max 250mA

Amount	Configurability	Details
2	Digital input, use only with Vref RS232	Low<3.5V, High>5V, max 100Hz
6	Digital input Analog input	Low<3.5V, High>5V, max 100Hz 12-bit AD conv., 0-10.3V/0-22mA
8	Digital input Digital output Current controlled PWM output	Low<3.5V, High>5V, max 100Hz High side switch, max. 3A High side switch, max. 3A
4	Digital input Frequency/pulse input/Quadrature Digital output PWM output	Low<3.5V, High>5V, max 100Hz Low<3.5V, High>5V, max 8kHz High side switch, max. 3A High side switch, max. 3A

Inclinometer and Gyro

The product has built-in inclinometer and gyro. The data from both of them is brought to CAN bus as default:

TPDO5	Description	Details
Byte 0	X angle	-900 ... +900 [equals -90.0° ... +90.0°]
Byte 2	Y angle	-900 ... +900 [equals -90.0° ... +90.0°]
Byte 4	X angle speed	10=1.0 °/s, resolution 0.2
Byte 6	X angle speed	10=1.0 °/s, resolution 0.2

TPDO6	Description	Details
Byte 0	X angle acceleration	10=1.0 °/s ² , resolution 0.4
Byte 2	Y angle in acceleration	10=1.0 °/s ² , resolution 0.4
Byte 4	X/Y full rotation	-1800 ... +1800 [equals -180.0° ... +180.0°]
Byte 6	Vibration frequency	1=1Hz *)

*) The measurement axis can be selected over object 2027h

TPDO7	Description	Details
Byte 0	Z angle gyro speed	10=1.0 °/s, accuracy 0.1
Byte 2	Z angle gyro	-1800 ... +1800 [equals -180.0° ... +180.0°]
Byte 4	X/Y full rotation with gyro	-1800 ... +1800 [equals -180.0° ... +180.0°]
Byte 6	Z angle gyro internal error	0 or 1, 1=error

The “X/Y full rotation with gyro” uses gyro to compensate interference from acceleration, vibration and shock.

Wiring Diagram:

Analog inputs

12-bit resolution
0-10.3V / 0-22mA

or

Digital inputs

or

Node ID selection

only AI_4

Reference voltage out

250mA

Digital inputs

or

RS232

ISO high speed CAN

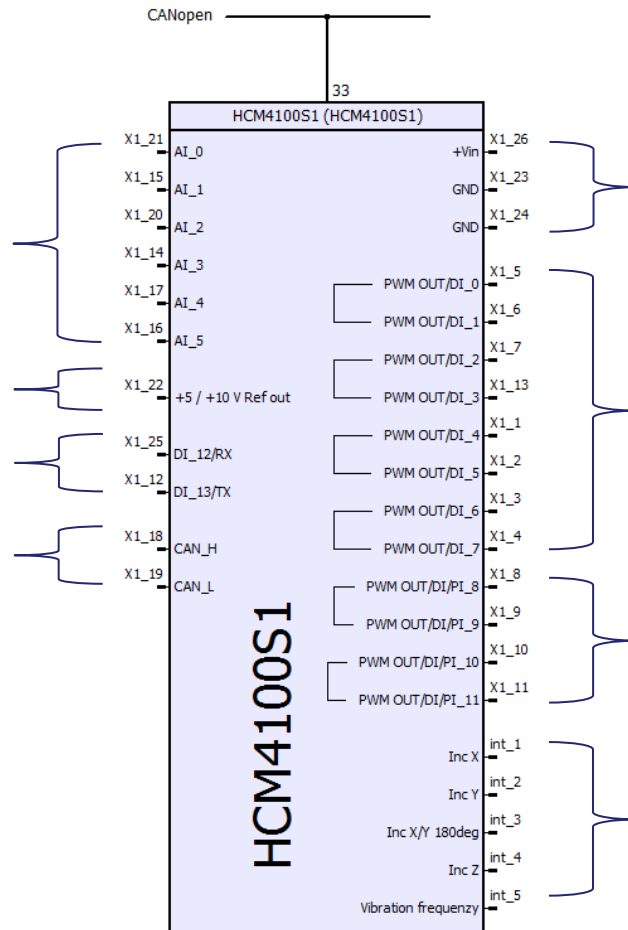

Supply

Max 10A fuse

Digital outputs

High side driver, Max 3A

or

PWM outputs

with current measurement

High side driver, Max 3A

or

Digital inputs

Digital outputs

High side driver, Max 3A

or

PWM outputs

High side driver, Max 3A

or

Digital inputs

or

Pulse/Frequency inputs

Internal angle outputs

For use in programming

Node ID

As default the unit Node address is set by voltage level at AI_4.

Voltage at AI_4	Node ID offset	Rx / Ω
0V	1	open
1.7V	3	150k
3.5V	5	33k
5.2V	7	0
6.9V	9	n/a
8.7V	11	n/a
10.4V	13	n/a

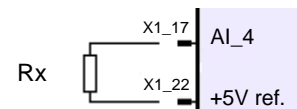

Node ID = Base Node ID (32) + Node ID offset

See also product's CANopen profile for further details.

Connector

Tyco Electronics Super Seal Connector

Connector components needed:

Super Seal Connector Plug Housing	AMP 3-1437290-7
Receptacle Contact (0.75 – 1.25mm ²)	AMP 3-1447221-3
Filler Plug ^{*)}	AMP 4-1437284-3 Deutsch 0413-204-2005

^{*)} Filler plugs must be used to reach waterproofness

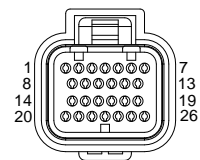

As seen from cable entry side

Tests & CE compliance – tests still pending

EMC	<p>EN 61000-4-2, Testing and measurement techniques – Electrostatic discharge immunity test E/ECE Regulation No. 10, Revision 4 (2012), Emission and immunity tests</p> <p>IEC 60255-22-1, Electrical disturbance tests for measuring relays and protection equipment – 1 MHz burst immunity test</p>
Environmental	<p>EN 60068-2-1, Cold test</p> <p>IEC 60068-2-2, Dry heat test</p> <p>IEC 60068-2-30, Damp heat test</p> <p>EN 60068-2-6, Stationary vibration</p> <p>EN 60068-2-27, Mechanical shock test</p> <p>IEC 60529, IP6X dust test</p> <p>IEC 60529, IPX7 temporary inversion test to 1m</p> <p>ISO 9227, Salt spray test</p>

Mounting and Housing Dimensions

HCM4100S1 is fixed to flat surface with four M5 screws. The recommended mounting position is AMP connector facing down or to the side. In latter case it is recommended to leave some loose cable hanging in downward arc to prevent any moisture from accessing the module through the connector.

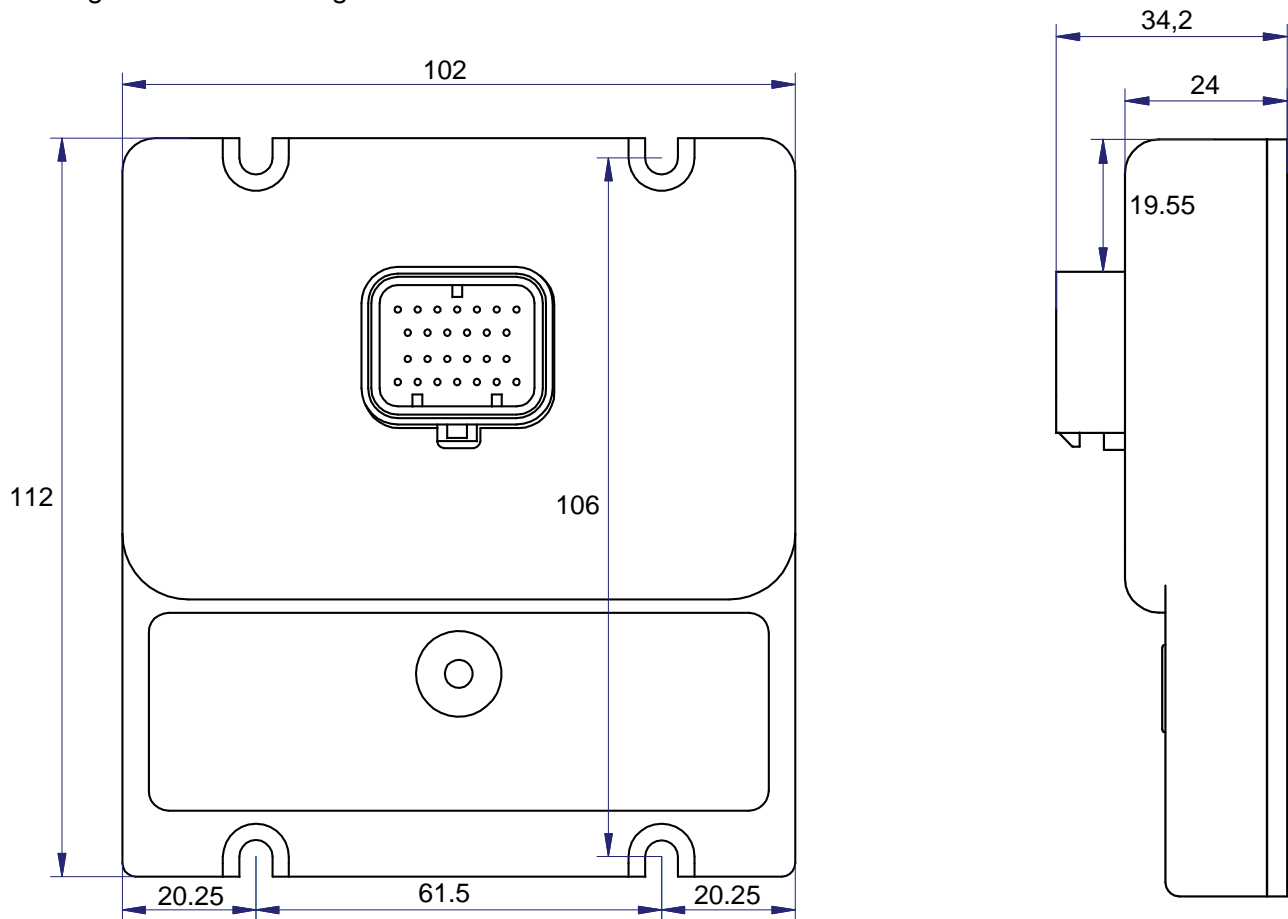

Exertus reserves the rights to change product details without prior notice.