

Technical Information

Joysticks

JS120 Single Axis Fingertip Joystick

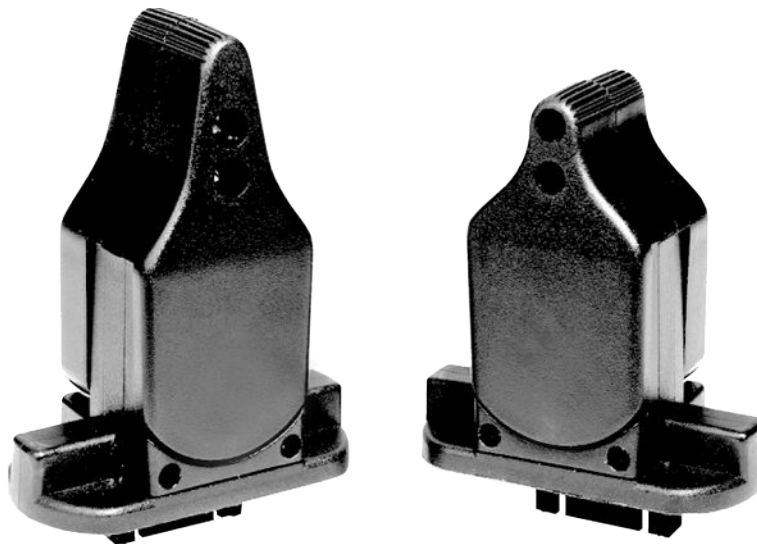

Revision history*Table of revisions*

Date	Changed	Rev
June 2019	Reverse the order of the pins instead of G-A going down, it is A-G going down	0401
October 2017	Cable 10101762 is obsolete, replaced with part number 162U1010	0304
December 2016	Corrected pinout drawing	0303
April 2016	Updated to Engineering Tomorrow design	0302
November 2015	Converted to Danfoss layout	0301
July 2009	Corrected connector pin assignments and added output voltage curve	DA
February 2007	Lever length options; connector pin assignments	CA
May 2006	Model code number	BA
May 2006	Typical contact resistance to ohms	AA

Contents**Overview**

JS120 description.....	4
Features and options.....	4

Product configuration model code

Model code summary.....	5
Center tap	6
Padding resistors	6
Position switches.....	6

Product installation

Dimensions and mounting.....	7
Connector pin assignments.....	8
Mating connector details.....	8
Machine wiring guidelines.....	9
Joystick safety.....	9
Joystick dust and water protection.....	9
Joystick safety critical functions.....	10

Product specifications

Electrical characteristics.....	11
Mechanical characteristics.....	11
Environmental parameters	12

Overview

JS120 description

Danfoss has developed the JS120 base to meet the harsh operating requirements of today's mobile machine market.

Developed for applications where ergonomics and system integrity are paramount, the JS120 is a minimum width, low profile joystick that provides precise fingertip control in one axis. The low profile lever makes the JS120 less susceptible to unintentional operation and the minimum under-panel footprint makes it ideal for mounting in panels and operator arm rests. The JS120 is sealed to IP 66 above panel to enable it to operate in extreme environments.

Designed for use with electronic controllers, the joystick generates analog and switched reference signals proportional to the distance and direction over which the handle is moved. The output is configured to provide signals for fault detection circuits and a center tap provides an accurate voltage reference for the lever in its released position, or a zero point for a bipolar supply voltage. Electrically independent direction switches are also available.

This publication describes the technical features and data required to specify the JS120 base for your application.

Features and options

- Long life potentiometric sensing
- Single axis
- Spring center return and end return options
- Slim profile with low operating forces
- Easy installation
- Operating life > 5 million cycles
- Output options
 - 10 to 90 % Vs
 - 25 to 75 % Vs
- IP 66 environmental sealing above panel
- Independent direction switch signals
- Width only 26.5 mm (1.04 in)
- Ergonomic design
- Choice of two lever heights

Product configuration model code

The product configuration model code specifies particular features when ordering the JS120. The model code begins with the product family name and the remaining fields are filled in to configure the product with the desired features.

Model code summary

Product configuration model code sample

A	B
JS120	0002

A—Product series

Code	Description
JS120	Series JS120 Joystick

B—Lever length and output voltage range options

Code	Description
0002	Short lever, 10 to 90% Vs output range, 5 kΩ, spring return to center
0003	Short lever, 25 to 75% Vs output range, 5 kΩ, spring return to center
0005	Long lever, 10 to 90% Vs output range, 5 kΩ, spring return to center
0006	Long lever, 25 to 75% Vs output range, 5 kΩ, spring return to center
0008	Long lever, 10 to 90% Vs output range, 5 kΩ, spring return to end
0009	Long lever, 25 to 75% Vs output range, 5 kΩ, spring return to end
0010	Short lever, 10 to 90% Vs output range, 5 kΩ, spring return to end
0011	Short lever, 25 to 75% Vs output range, 5 kΩ, spring return to end

Vs = supply voltage

Product configuration model code
Center tap

A center tap (spring return to center option) is a standard JS120 feature, where 50% of the supply voltage can be supplied to force the sensor voltage to this known reference. When the center tap is not connected there will be a center dead band (where the voltage output does not change on initial deflection).

Padding resistors

The JS120 potentiometer track has resistors placed in series with the main resistive element. These resistors are used to reduce the outputs at full mechanical deflection. This is a safety feature that the machine control system can use to determine a broken wire or short circuit to full voltage or ground. The degree to which the output is reduced can be chosen from the Code B table in [Model code summary](#) on page 5.

Position switches

Position switches are a standard JS120 feature. The normally open switches close at the angles specified in the table below indicating forward and reverse travel of the lever. These switches are connected independently of the proportional potentiometric elements and can be terminated by the customer to provide center on/off data to the control system.

Specifications

Switch operating angle	5° either side of center ($\pm 1^\circ$ tolerance)
Maximum supply voltage—maximum V_s	< 35 Vdc
Minimum load resistance	10 k Ω
Maximum load current	2 mA resistive
Typical contact resistance	150 Ω

Product installation

Dimensions and mounting

Dimensions

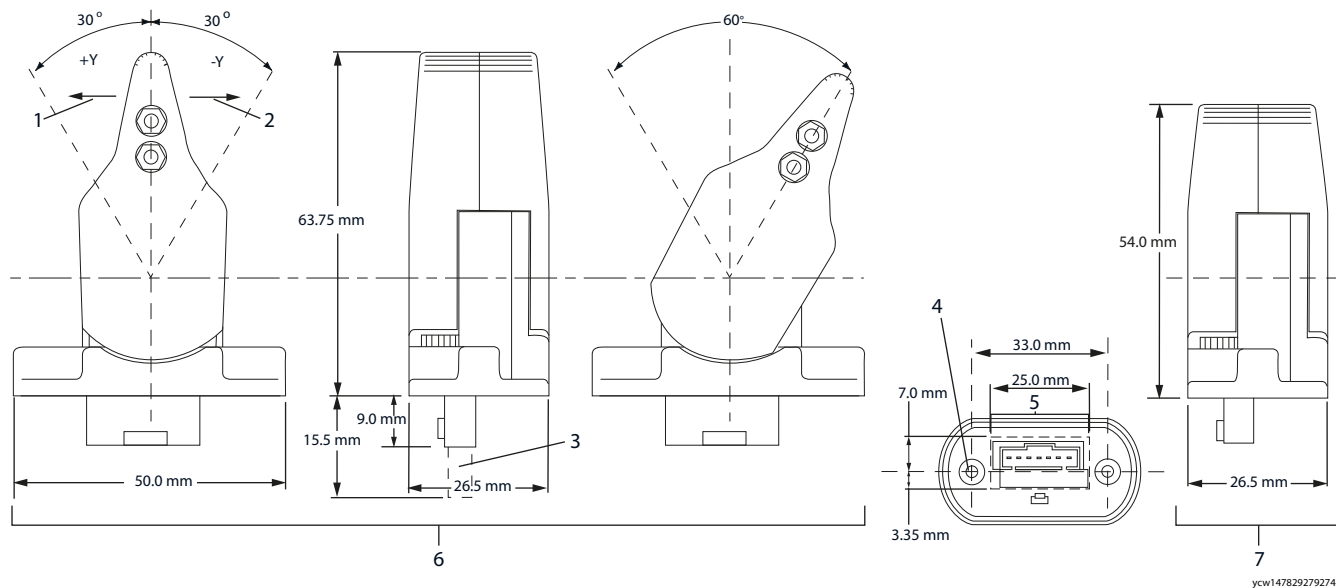

ycw1478292792742

- | | |
|------------------|----------------------------------|
| 1. Forward | 2. Backward |
| 3. Connector | 4. Panel clearance holes 3.10 mm |
| 5. Panel cut out | 6. Long lever |
| 7. Short lever | |

JS120 is designed to be fitted down into the panel, through the panel cutout. Panel seal integrity can be achieved by using sealing gasket. Mounting screws can be driven to a recommended torque of 1 N·m (9 lbf·in). The joystick is fitted with 2 x M3 inserts and the maximum screw penetration is 6 mm plus panel thickness.

Product installation

Connector pin assignments

Connector

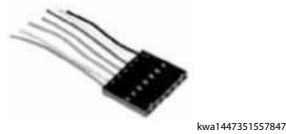

Pin assignments (connector end view)

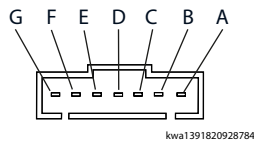

Pinout and wiring information

Pin	JS120-0002, 0003, 0005, 0006	JS120-0008, 0009, 0010, 0011
A	Center tap	Not used
B	(+) supply (power)	(+) supply (power)
C	Output voltage	Output voltage
D	(-) supply (ground)	(-) supply (ground)
E	Direction switch -Y (N/O)	Not used
F	Direction switch +Y (N/O)	Direction switch (N/O)
G	Direction switch common	Direction switch common

[Marker on underside of mating connector indicates pin G](#)

Mating connector details

Mating connector – AMPMODU MTE series

Connector	AMP ordering number
7 pin latching male	103957-6

Mating connector assembly

Type	Danfoss ordering number
7 pin with 610 mm [24.02 in] leads	162U1010

Product installation

Machine wiring guidelines

Warning

Unintended movement of the machine or mechanism may cause injury to the technician or bystanders. Improperly protected power input lines against over current conditions may cause damage to the hardware. Properly protect all power input lines against over-current conditions. To protect against unintended movement, secure the machine.

Caution

Unused pins on mating connectors may cause intermittent product performance or premature failure. Plug all pins on mating connectors.

- Protect wires from mechanical abuse, run wires in flexible metal or plastic conduits.
- Use 85° C (185° F) wire with abrasion resistant insulation and 105° C (221° F) wire should be considered near hot surfaces.
- Use a wire size that is appropriate for the module connector.
- Separate high current wires such as solenoids, lights, alternators or fuel pumps from sensor and other noise-sensitive input wires.
- Run wires along the inside of, or close to, metal machine surfaces where possible, this simulates a shield which will minimize the effects of EMI/RFI radiation.
- Do not run wires near sharp metal corners, consider running wires through a grommet when rounding a corner.
- Do not run wires near hot machine members.
- Provide strain relief for all wires.
- Avoid running wires near moving or vibrating components.
- Avoid long, unsupported wire spans.
- Ground electronic modules to a dedicated conductor of sufficient size that is connected to the battery (-).
- Power the sensors and valve drive circuits by their dedicated wired power sources and ground returns.
- Twist sensor lines about one turn every 10 cm (4 in).
- Use wire harness anchors that will allow wires to float with respect to the machine rather than rigid anchors.

Joystick safety

Joystick dust and water protection

The joystick is sealed above the mounting surface to prevent dust and water ingress and is supplied with a sealing gasket for mounting above the panel. The effectiveness of the seal is dependent on the mounting surface being sufficiently rigid to compress the sealing gasket. The finish of the mounting surface is critical to achieving an adequate seal and rough surface finishes, paint chips, deep scratches, etc. should be avoided.

The joystick base below the mounting surface should be protected from dust and direct water spray.

Product installation**Joystick safety critical functions**

For a system to operate safely it must be able to differentiate between commanded and uncommanded inputs. Take steps to detect and manage joystick and system failures that may cause an erroneous output.

For safety critical functions Danfoss recommends you use an independent momentary action system enable switch. You can incorporate this switch into the joystick as an operator presence switch or can be a separate foot or hand operated momentary switch. Disable all joystick functions that the joystick controls when this switch is released.

Ensure the control system looks for the appropriate system enable switch input before the joystick is displaced from its neutral position. Enable functions only after receiving this input.

Applications using CAN joysticks should continuously monitor for the presence of the CAN messages on periodic basis. Messages are to be checked frequently enough for the system or operator to react if the CAN messages lose priority or are no longer received.

Product specifications

Electrical characteristics

Electrical characteristics

Sensor type	Potentiometric
Electrical angle of movement center return	28° ± 1°
Electrical angle of movement end return	Start 2° ± 1°, end return full angle 56° ± 1°
Total track resistance	5 kΩ (± 20%)
Maximum supply voltage (Vs)	35 Vdc
Maximum wiper current	5 mA (non-destructive)
Maximum power dissipation	0.25 W at 20°C [68°F]
Wiper circuit impedance	200 kΩ minimum
Output voltage	10 to 90% Vs 25 to 75% Vs
Resolution	Infinite
Center tap voltage (no load)	50% Vs ± 2%
Center tap angle (center return)	± 2.5° either side of center (± 1° tolerance)
Insulation resistance	> 50 MΩ at 500 Vdc
Load resistance minimum	10 kΩ
Load current maximum	2 mA resistive

Output voltage curve

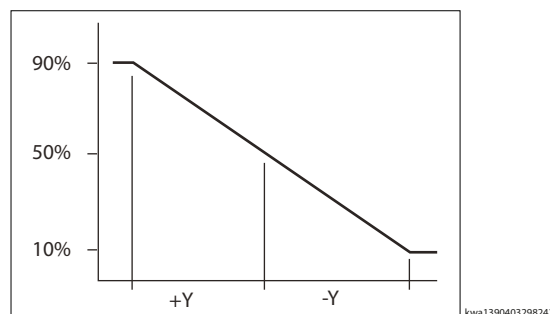

Mechanical characteristics

Mechanical characteristics

Description	Short lever	Long lever
Breakout force (at lever tip)	3.1 N [0.70 lbf]	2.3 N [0.52 lbf]
Operating force (at tip, full deflection)	5.1 N [1.15 lbf]	3.4 N [0.76 lbf]
Maximum allowable force	50 N [11.24 lbf]	35 N [7.87 lbf]
Lever operating angle	30° ± 1° center return 60° ± 1° end return	
Lever action	Self centering or end return	
Expected life	> 5 million cycles	
Weight	0.045 kg [0.099 lb]	

Product specifications

Environmental parameters

Environmental parameters

Operating temperature	-25°C to 70°C [-13°F to 158°F]
Storage temperature	-40°C to 85°C [-40°F to 185°F]
Environmental sealing above the flange	IP 66 above panel, IP 40 below panel

Products we offer:

- DCV directional control valves
- Electric converters
- Electric machines
- Electric motors
- Hydrostatic motors
- Hydrostatic pumps
- Orbital motors
- PLUS+1® controllers
- PLUS+1® displays
- PLUS+1® joysticks and pedals
- PLUS+1® operator interfaces
- PLUS+1® sensors
- PLUS+1® software
- PLUS+1® software services, support and training
- Position controls and sensors
- PVG proportional valves
- Steering components and systems
- Telematics

Danfoss Power Solutions is a global manufacturer and supplier of high-quality hydraulic and electric components. We specialize in providing state-of-the-art technology and solutions that excel in the harsh operating conditions of the mobile off-highway market as well as the marine sector. Building on our extensive applications expertise, we work closely with you to ensure exceptional performance for a broad range of applications. We help you and other customers around the world speed up system development, reduce costs and bring vehicles and vessels to market faster.

Danfoss Power Solutions – your strongest partner in mobile hydraulics and mobile electrification.

Go to www.danfoss.com for further product information.

We offer you expert worldwide support for ensuring the best possible solutions for outstanding performance. And with an extensive network of Global Service Partners, we also provide you with comprehensive global service for all of our components.

Hydro-Gear

www.hydro-gear.com

Daikin-Sauer-Danfoss

www.daikin-sauer-danfoss.com

Local address:

**Danfoss
Power Solutions (US) Company**
2800 East 13th Street
Ames, IA 50010, USA
Phone: +1 515 239 6000

**Danfoss
Power Solutions GmbH & Co. OHG**
Krokamp 35
D-24539 Neumünster, Germany
Phone: +49 4321 871 0

**Danfoss
Power Solutions ApS**
Nordborgvej 81
DK-6430 Nordborg, Denmark
Phone: +45 7488 2222

**Danfoss
Power Solutions Trading
(Shanghai) Co., Ltd.**
Building #22, No. 1000 Jin Hai Rd
Jin Qiao, Pudong New District
Shanghai, China 201206
Phone: +86 21 3418 5200

Danfoss can accept no responsibility for possible errors in catalogues, brochures and other printed material. Danfoss reserves the right to alter its products without notice. This also applies to products already on order provided that such alterations can be made without subsequent changes being necessary in specifications already agreed. All trademarks in this material are property of the respective companies. Danfoss and the Danfoss logotype are trademarks of Danfoss A/S. All rights reserved.